

# THC63LVDM83D

## 24bit COLOR LVDS TRANSMITTER

### General Description

The THC63LVDM83D transmitter is designed to support pixel data transmission between Host and Flat Panel Display up to 1080p/WUXGA resolutions.

The THC63LVDM83D converts 28bits of LVCMOS data into four OpenLDI(LVDS) data streams. The transmitter can be programmed for rising edge or falling edge clock through a dedicated pin. At a transmit clock frequency of 160MHz, 24bits of RGB data and 4bits of timing and control data (HSYNC, VSYNC, DE, CONT1) are transmitted at an effective rate of 1120Mbps per OpenLDI(LVDS) channel.

### Application

- Medium and Small Size Panel
- Tablet PC / Notebook PC
- Security Camera / Industrial Camera
- Multi Function Printer
- Industrial Equipment
- Medical Equipment Monitor

### Features

- Compatible with TIA/EIA-644 LVDS Standard
- 7:1 OpenLDI(LVDS) Transmitter
- Operating Temperature Range : 0 to +70°C
- No Special Start-up Sequence Required
- Spread Spectrum Clocking Tolerant up to 100kHz Frequency Modulation and +/-2.5% Deviations.
- Wide Dot Clock Range: 8 to 160MHz Suited for  
TV Signal : NTSC(12.27MHz) - 1080p(148.5MHz)  
PC Signal : QVGA(8MHz) - WUXGA(154MHz)
- 56pin TSSOP Package
- 1.2V to 3.3V LVCMOS/ inputs are supported.
- LVDS swing is reducible as 200mV by RS-pin to reduce EMI and power consumption.
- PLL requires no external components.
- Power Down Mode.
- Input clock triggering edge is selectable by R/F-pin
- EU RoHS Compliant.

### Block Diagram

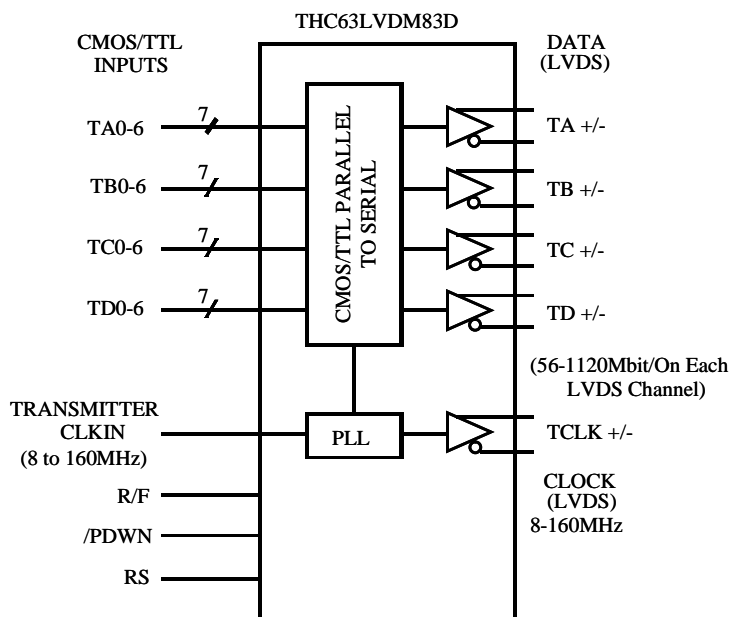
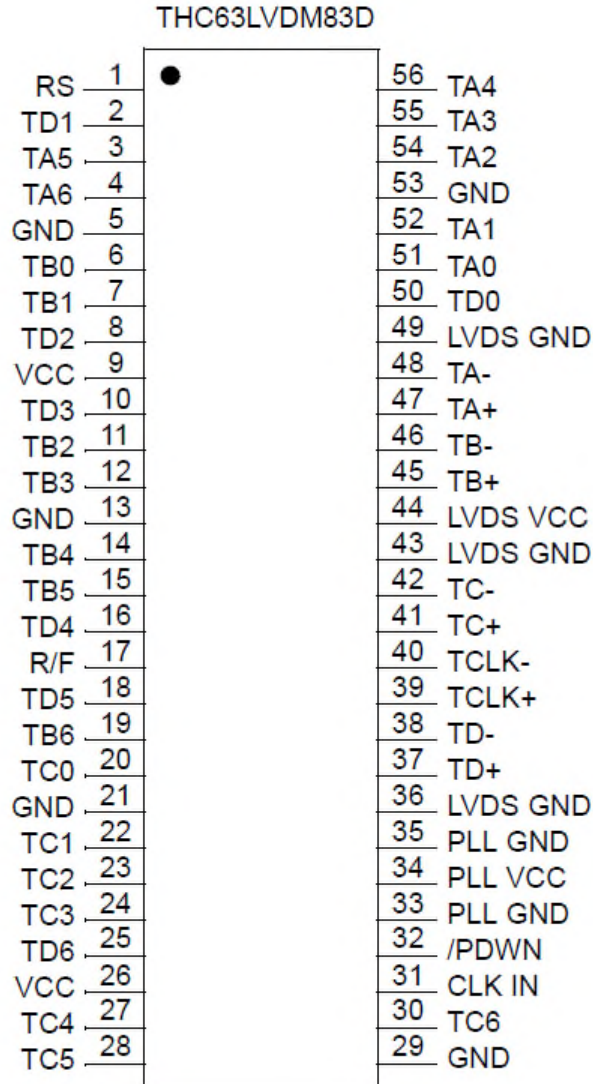

Figure 1. Block Diagram

Pin Diagram



**Figure 2. Pin Diagram**

**Pin Description**

Pin Name	Pin #	Direction	Type	Description												
TA+, TA-	47, 48	Output	LVDS	LVDS Data Out												
TB+, TB-	45, 46															
TC+, TC-	41, 42															
TD+, TD-	37, 38															
TCLK+, TCLK-	39, 40			LVDS Clock Out												
TA0 ~ TA6	51, 52, 54, 55, 56, 3, 4	Input	LVCMOS	Pixel Data Input												
TB0 ~ TB6	6, 7, 11, 12, 14, 15, 19															
TC0 ~ TC6	20, 22, 23, 24, 27, 28, 30															
TD0 ~ TD6	50, 2, 8, 10, 16, 18, 25															
/PDWN	32			H : Normal Operation L : Power Down (All outputs are Hi-Z)												
RS	1			LVDS Swing Mode, VREF Select See Fig.7, 8												
				<table border="1"> <thead> <tr> <th>RS Pin</th> <th>LVDS Swing</th> <th>Small Swing Input Support</th> </tr> </thead> <tbody> <tr> <td>VCC</td> <td>350mV</td> <td>N/A</td> </tr> <tr> <td>0.6 to 1.4V</td> <td>350mV</td> <td>RS=VREF</td> </tr> <tr> <td>GND</td> <td>200mV</td> <td>N.A</td> </tr> </tbody> </table>	RS Pin	LVDS Swing	Small Swing Input Support	VCC	350mV	N/A	0.6 to 1.4V	350mV	RS=VREF	GND	200mV	N.A
RS Pin	LVDS Swing			Small Swing Input Support												
VCC	350mV			N/A												
0.6 to 1.4V	350mV			RS=VREF												
GND	200mV	N.A														
R/F	17	VREF : is Input Reference Voltage Input Clock Triggering Edge Select H : Rising Edge L : Falling Edge														
CLKIN	31	Input Clock														
VCC	9, 26	Power	-	Power Supply Pins for LVCMOS inputs and digital circuit.												
GND	5, 13, 21, 29, 53			Ground Pins for LVCMOS Inputs and Digital Circuitry.												
LVDS VCC	44			Power Supply Pins for LVDS Outputs.												
LVDS GND	36, 43 49			Ground Pins for LVDS Outputs.												
PLL VCC	34			Power Supply Pin for PLL Circuitry.												
PLL GND	33, 35			Ground Supply Pin for PLL Circuitry.												

**Table 1. Pin Description**

**Absolute Maximum Ratings**

Parameter	Min	Max	Unit
All Supply Voltage (VCC, LVDS VCC, PLL VCC)	-0.3	+4.0	V
LVC MOS Input Voltage	-0.3	VCC + 0.3	V
LVDS Output Pin	-0.3	VCC + 0.3	V
Output Current	-30	30	mA
Junction Temperature	-	+125	°C
Storage Temperature	-55	+150	°C
Reflow Peak Temperature	-	+260	°C
Reflow Peak Temperature Time	-	10	sec
Maximum Power Dissipation @+25°C	-	1.8	W

**Table 2. Absolute Maximum Ratings**

**Recommended Operating Conditions**

Symbol	Parameter	Min	Typ	Max	Unit
VCC, LVDS VCC PLL VCC	All Supply Voltage	3.0	3.3	3.6	V
Ta	Operating Ambient Temperature	0	25	+70	°C
-	Clock Frequency	8	-	160	MHz

**Table 3. Recommended Operating Conditions**

“Absolute Maximum Ratings” are those values beyond which the safety of the device can not be guaranteed. They are not meant to imply that the device should be operated at these limits. The tables of “Electrical Characteristics Table 4, 5, 6, 7” specify conditions for device operation.

“Absolute Maximum Rating” value also includes behavior of overshooting and undershooting.

**Equivalent LVDS Output Schematic Diagram**

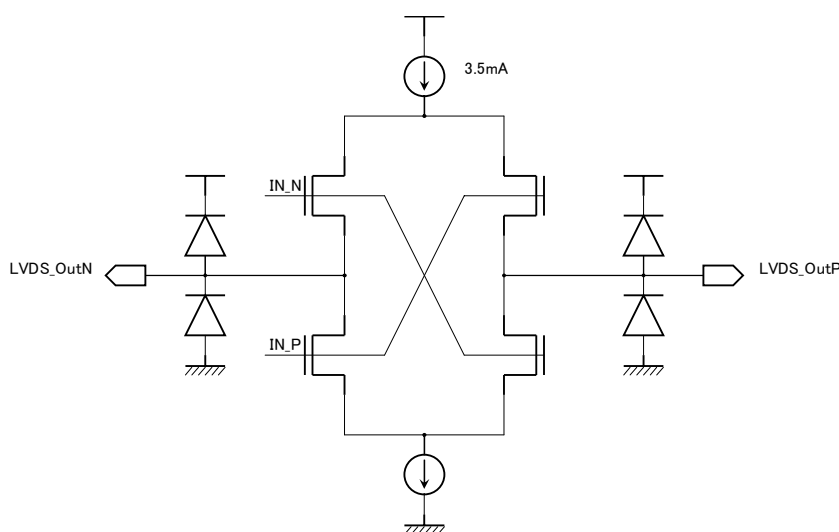

**Figure 3. LVDS Output Schematic Diagram**

**Power Consumption**

Over recommended operating supply and temperature range unless otherwise specified

Symbol	Parameter	Conditions	Typ*	Max	Unit
I <sub>TCCW</sub>	LVDS Transmitter Operating Current Worst Case Pattern (Fig.4)	RL=100Ω, CL=5pF, f=85MHz, RS=VCC	61	67	mA
		RL=100Ω, CL=5pF, f=135MHz, RS=VCC	77	83	mA
		RL=100Ω, CL=5pF, f=160MHz, RS=VCC	84	92	mA
		RL=100Ω, CL=5pF, f=85MHz, RS=GND	50	56	mA
		RL=100Ω, CL=5pF, f=135MHz, RS=GND	65	71	mA
		RL=100Ω, CL=5pF, f=160MHz, RS=GND	73	80	mA
I <sub>TCCS</sub>	LVDS Transmitter Power Down Current	/PDWN=L, All Inputs=L or H	-	10	μA

\*Typ values are at the conditions of VCC=3.3V and Ta = +25°C

**Table 4. Power Consumption**

**Worst Case Pattern**

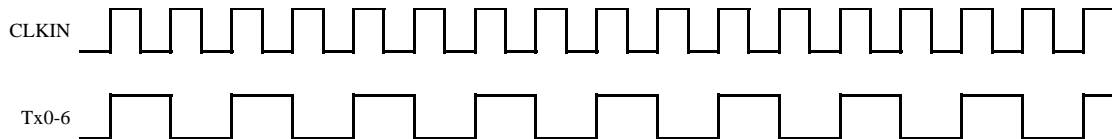

x=A,B,C,D

**Figure 4. Worst Case Pattern**

## Electrical Characteristics

### LVC MOS DC Specifications

Over recommended operating supply and temperature range unless otherwise specified

Symbol	Parameter	Conditions	Min	Typ*	Max	Unit
$V_{IH}$	High Level Input Voltage	$RS=VCC$ or GND	2.0	-	VCC	V
$V_{IL}$	Low Level Input Voltage	$RS=VCC$ or GND	GND	-	0.8	V
$V_{DDQ}^1$	Small Swing Voltage		1.2	-	2.8	V
$V_{REF}$	Input Reference Voltage	Small Swing ( $RS=V_{DDQ}/2$ )	-	$V_{DDQ}/2$	-	
$V_{SH}^2$	Small Swing High Level Input Voltage	$V_{REF}=V_{DDQ}/2$	$V_{DDQ}/2$ +100mV	-	-	V
$V_{SL}^2$	Small Swing Low Level Input Voltage	$V_{REF}=V_{DDQ}/2$	-	-	$V_{DDQ}/2$ -100mV	V
$I_{INC}$	Input Current	$GND \leq V_{IN} \leq VCC$	-	-	$\pm 10$	$\mu A$

\*Typ values are at the conditions of  $VCC=3.3V$  and  $T_a = +25^\circ C$

Notes : <sup>1</sup>  $V_{DDQ}$  voltage defines the max voltage of small swing inputs at  $RS=V_{REF}$ . It is not an actual input voltage.

<sup>2</sup> Small swing signals are applied to TA0-6, TB0-6, TC0-6, TD0-6 and CLKIN.

**Table 5. LV-CMOS DC Specifications**

### LVDS Transmitter DC Specifications

Over recommended operating supply and temperature range unless otherwise specified

Symbol	Parameter	Conditions	Min	Typ*	Max	Unit
VOD	Differential Output Voltage	Normal swing $RS=VCC$	250	350	450	mV
		Reduced swing $RS=GND$	100	200	300	mV
$\Delta VOD$	Change in VOD between complementary output states	$RL=100\Omega$	-	-	35	mV
VOC	Common Mode Voltage		1.125	1.25	1.375	V
$\Delta VOC$	Change in VOC between complementary output states		-	-	35	mV
$I_{OS}$	Output Short Circuit Current	$V_{OUT}=GND, RL=100\Omega$	-	-	-24	mA
$I_{OZ}$	Output TRI-STATE Current	$/PDWN=GND, V_{OUT}=GND$ to VCC	-	-	$\pm 10$	$\mu A$

\*Typ values are at the conditions of  $VCC=3.3V$  and  $T_a = +25^\circ C$

**Table 6. LVDS Transmitter DC Specifications**

### LVC MOS & LVDS Transmitter AC Specifications

Over recommended operating supply and temperature range unless otherwise specified

Symbol	Parameter	Min	Typ	Max	Unit
$t_{TCIT}$	CLK IN Transition Time	-	-	5.0	ns
$t_{TCP}$	CLK IN Period	6.25	T	125	ns
$t_{TCH}$	CLK IN High Time	0.35T	0.5T	0.65T	ns
$t_{TCL}$	CLK IN Low Time	0.35T	0.5T	0.65T	ns
$t_{TCD}$	CLK IN to TCLK+/- Delay	-	3T	-	ns
$t_{TS}$	LVC MOS Data Setup to CLK IN	2.0	-	-	ns
$t_{TH}$	LVC MOS Data Hold from CLK IN	0.0	-	-	ns
$t_{LVT}$	LVDS Transition Time	-	0.6	1.5	ns
$t_{TOP1}$	Output Data Position0 (T=6.25ns ~ 20ns)	-0.15	0.0	+0.15	ns
$t_{TOP0}$	Output Data Position1 (T=6.25ns ~ 20ns)	T/7-0.15	T/7	T/7+0.15	ns
$t_{TOP6}$	Output Data Position2 (T=6.25ns ~ 20ns)	2T/7-0.15	2T/7	2T/7+0.15	ns
$t_{TOP5}$	Output Data Position3 (T=6.25ns ~ 20ns)	3T/7-0.15	3T/7	3T/7+0.15	ns
$t_{TOP4}$	Output Data Position4 (T=6.25ns ~ 20ns)	4T/7-0.15	4T/7	4T/7+0.15	ns
$t_{TOP3}$	Output Data Position5 (T=6.25ns ~ 20ns)	5T/7-0.15	5T/7	5T/7+0.15	ns
$t_{TOP2}$	Output Data Position6 (T=6.25ns ~ 20ns)	6T/7-0.15	6T/7	6T/7+0.15	ns
$t_{TPLL}$	Phase Lock Loop Set	-	-	10.0	ms

\*Typ values are at the conditions of VCC=3.3V and Ta = +25°C

Table 7. LVC MOS & LVDS Transmitter AC Specifications

#### LVC MOS Input

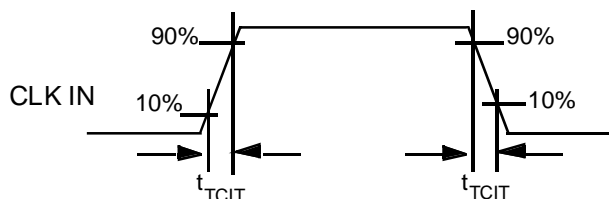
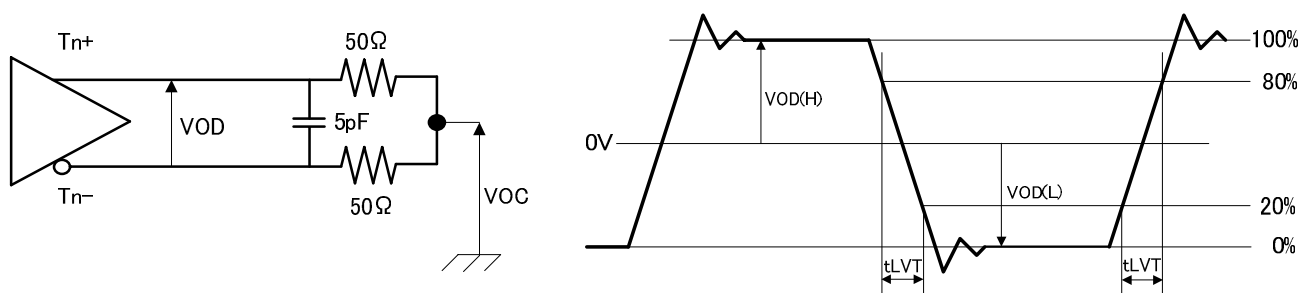

Figure 5. CLK IN Transmission Time

#### LVDS Output



#### LVDS Output Load

Figure 6. LVDS Output Load and Transmission Time

AC Timing Diagrams

LVC MOS Inputs

Normal Swing Input

RS	VOD
VCC	350mV
0.6 ~ 1.4V	
GND	200mV

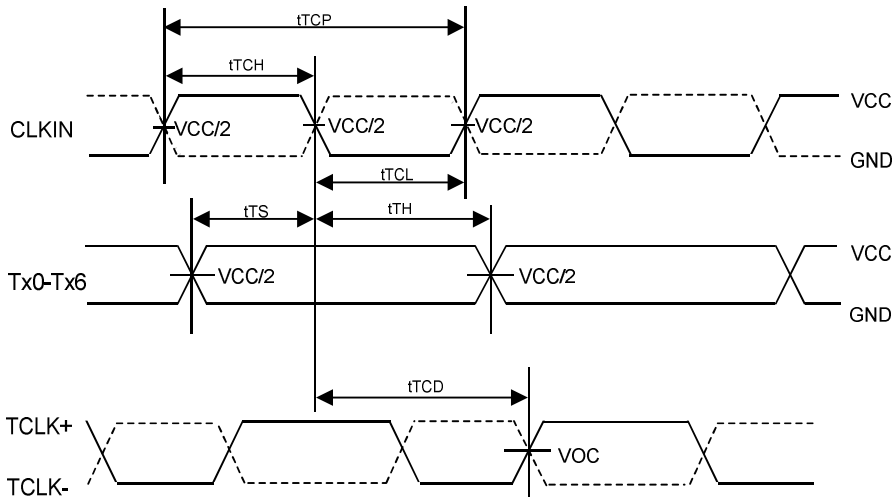

Note :  
 CLKIN : Solid line denotes the setting of R/F=GND  
 Dashed line denotes the setting of R/F = VCC

Figure 7. LVCOMS Inputs and LVDS Clock Output Timing 1

Small Swing Inputs

RS	VREF
VCC	---
0.6 ~ 1.4V	V <sub>DDQ</sub> /2
GND	---

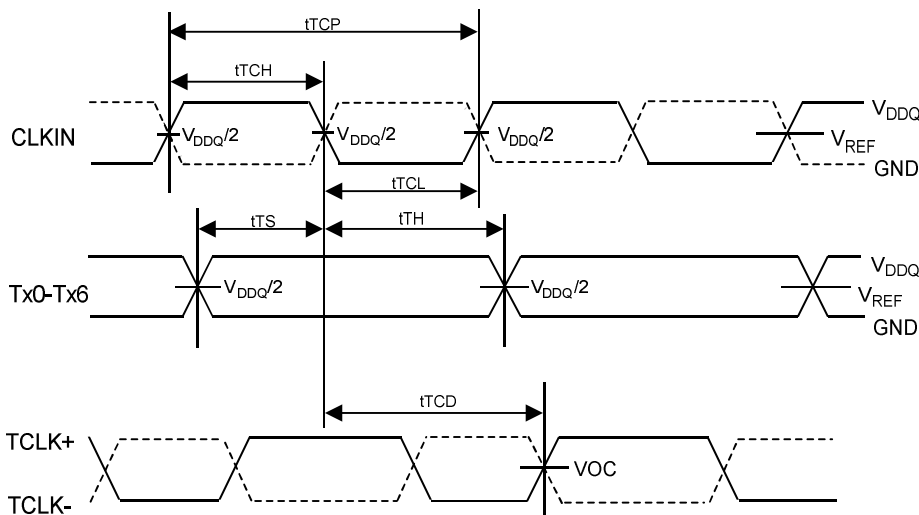

Note :  
 CLKIN : Solid line denotes the setting of R/F=GND  
 Dashed line denotes the setting of R/F = VCC

Figure 8. LVC MOS Inputs and LVDS Output Timing 2



LVDS Output Data Position

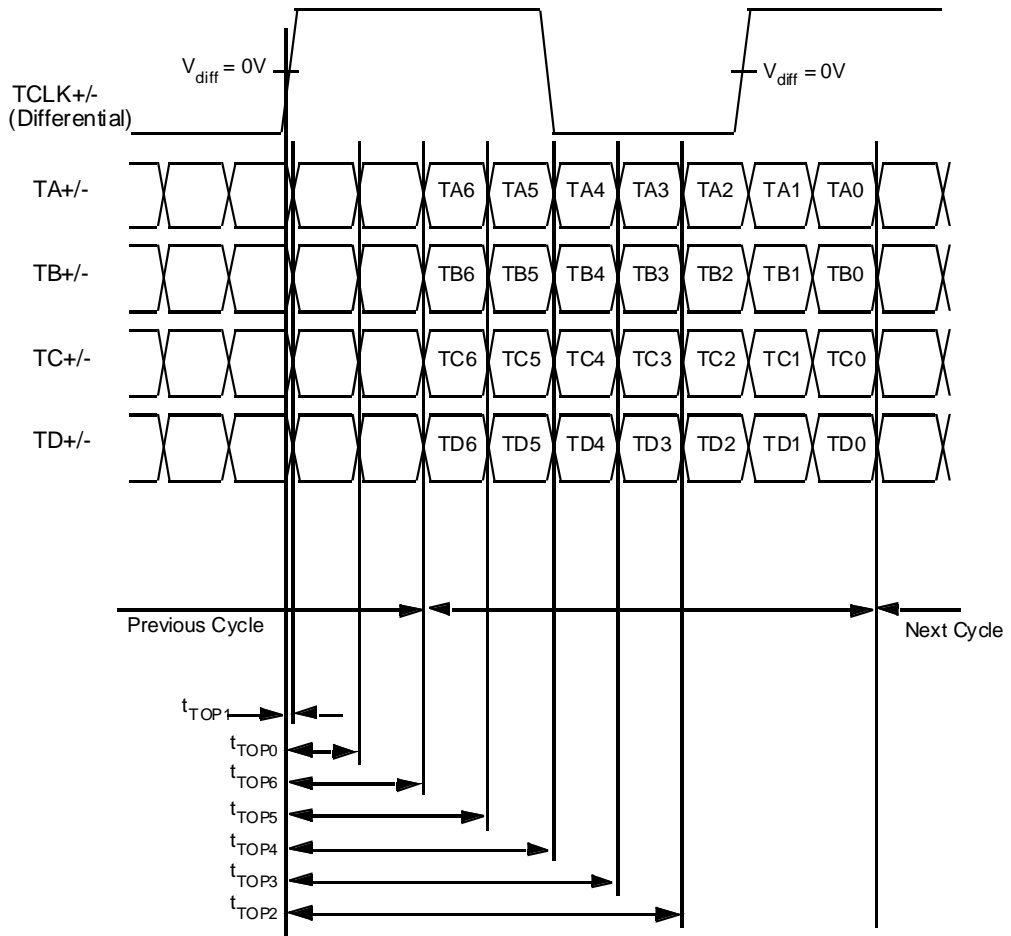

Figure 9. LVDS Output Data Position

Phase Lock Loop Set Time

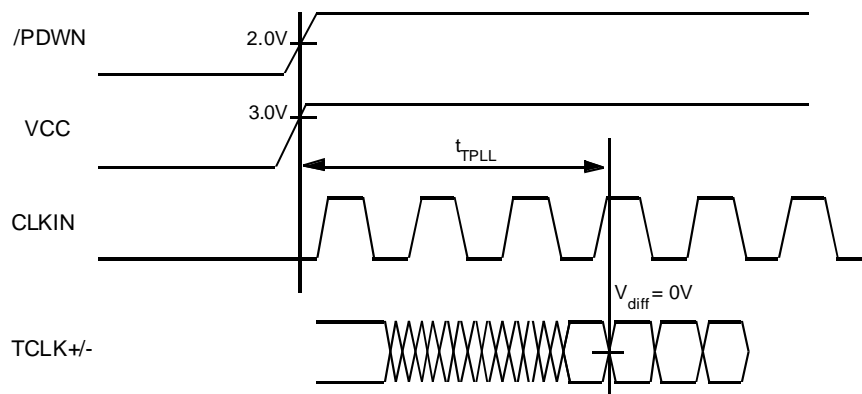
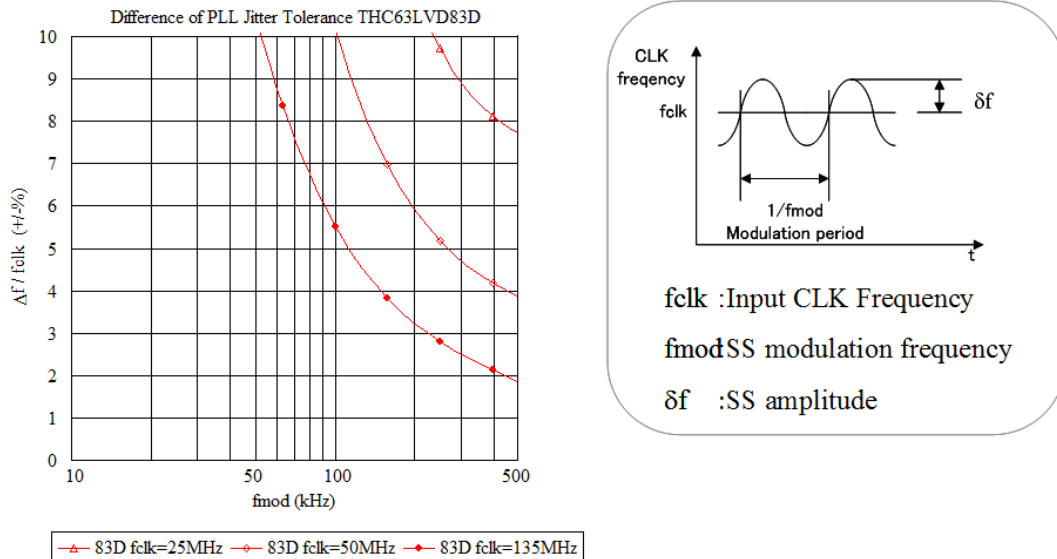

Figure 10. PLL Lock Loop Set Time

### Spread Spectrum Clocking Tolerant



**Figure 11. Spread Spectrum Clocking Tolerant**

The graph indicates the range that the IC works normally under SS clock input operation. The results are measured with a typical sample on condition of +25C° and 3.3V, therefore these values are for reference and do not guarantee the performance of a product under other circumstance.

### LVDS Data Timing Diagram

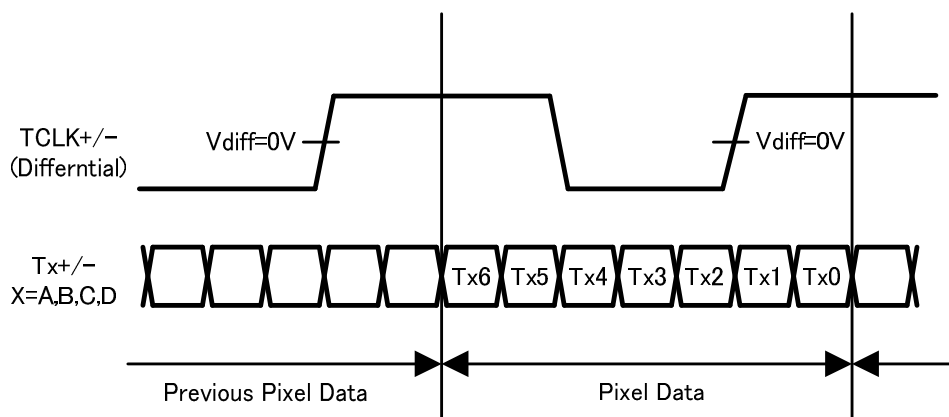

**Figure 12. LVDS Data Timing Diagram**

**For Display Application**

THC63LVDM83D Pixel Data Mapping for JEIDA Format (6bit, 8bit Application)

	6bit	8bit
TA0	R2	R2
TA1	R3	R3
TA2	R4	R4
TA3	R5	R5
TA4	R6	R6
TA5	R7	R7
TA6	G2	G2
TB0	G3	G3
TB1	G4	G4
TB2	G5	G5
TB3	G6	G6
TB4	G7	G7
TB5	B2	B2
TB6	B3	B3
TC0	B4	B4
TC1	B5	B5
TC2	B6	B6
TC3	B7	B7
TC4	Hsync	Hsync
TC5	Vsync	Vsync
TC6	DE	DE
TD0	-	R0
TD1	-	R1
TD2	-	G0
TD3	-	G1
TD4	-	B0
TD5	-	B1
TD6	-	N/A

Note : Use TA to TC channels and open TD channel for 6bit application.

**Table 8. Data Mapping for JEIDA Format**

THC63LVDM83D Pixel Data Mapping for VESA Format (6bit, 8bit Application)

	6bit	8bit
TA0	R0	R0
TA1	R1	R1
TA2	R2	R2
TA3	R3	R3
TA4	R4	R4
TA5	R5	R5
TA6	G0	G0
TB0	G1	G1
TB1	G2	G2
TB2	G3	G3
TB3	G4	G4
TB4	G5	G5
TB5	B0	B0
TB6	B1	B1
TC0	B2	B2
TC1	B3	B3
TC2	B4	B4
TC3	B5	B5
TC4	Hsync	Hsync
TC5	Vsync	Vsync
TC6	DE	DE
TD0	-	R6
TD1	-	R7
TD2	-	G6
TD3	-	G7
TD4	-	B6
TD5	-	B7
TD6	-	N/A

Note : Use TA to TC channels and open TD channel for 6bit application.

**Table 9. Data Mapping for VESA Format**

### Typical Connection

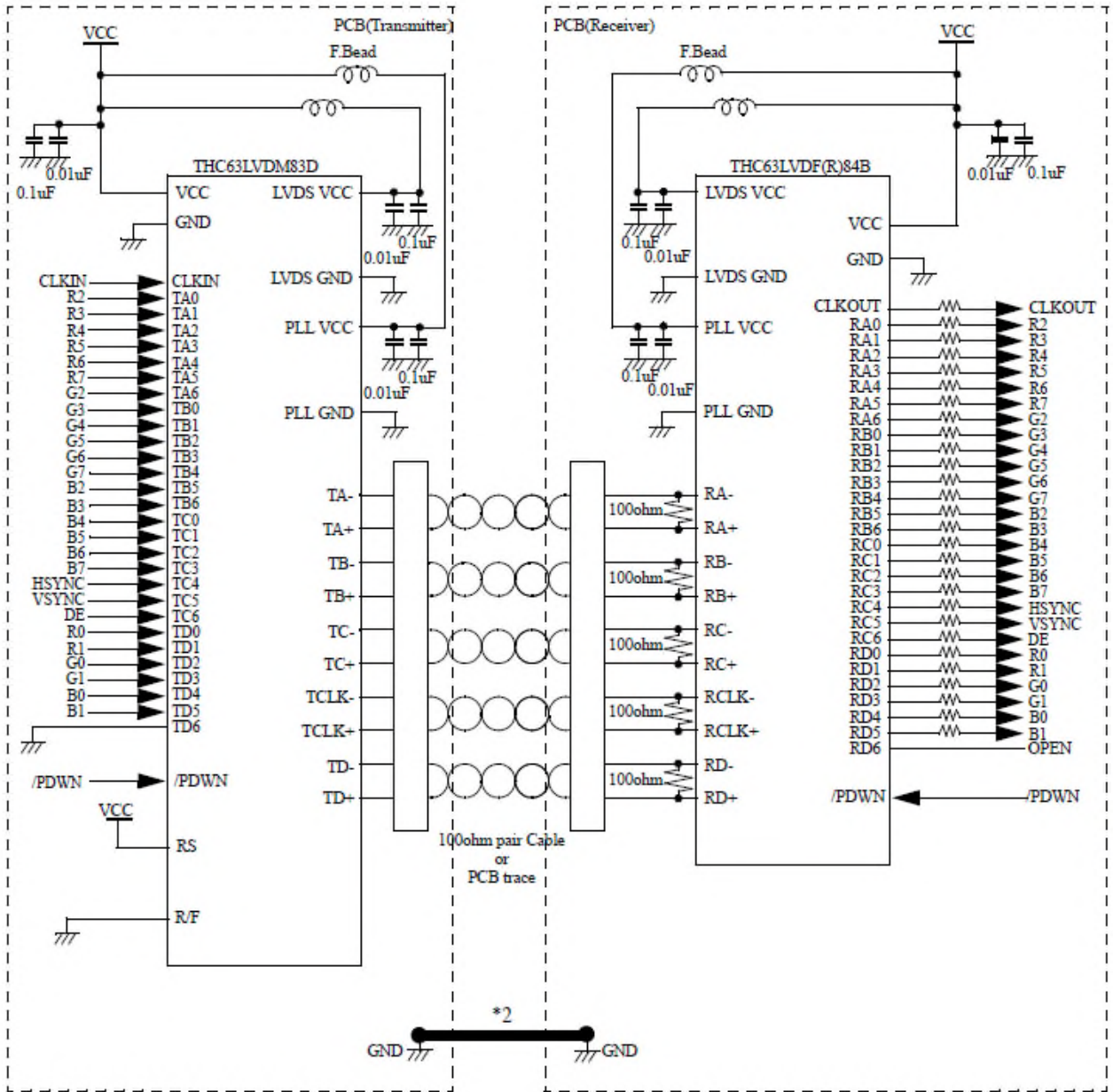

Figure 13. Typical Connection Diagram

Notes

1) Cable Connection and Disconnection

Do not connect and disconnect the LVDS cable, when the power is supplied to the system.

2) GND Connection

Connect each GND of the PCB which THC63LVDM83D and LVDS-Rx on it. It is better for EMI reduction to place GND cable as close to LVDS cable as possible.

3) Multi Drop Connection

Multi drop connection is not recommended.

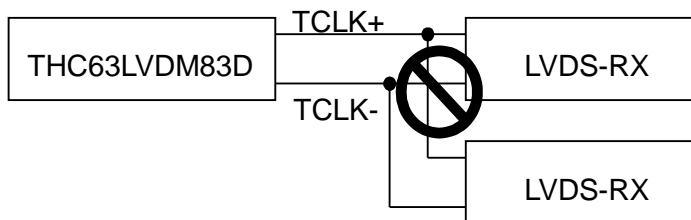

Figure 14. Multi Drop Connection

4) Asynchronous use

Asynchronous using such as following systems is not recommended.

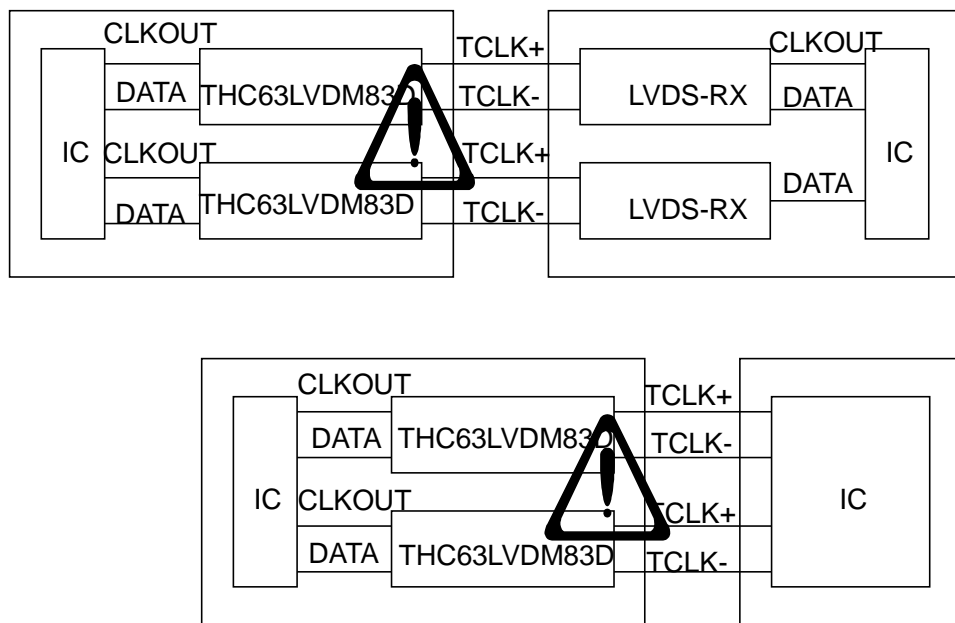

Figure 15. Asynchronous Use

Package

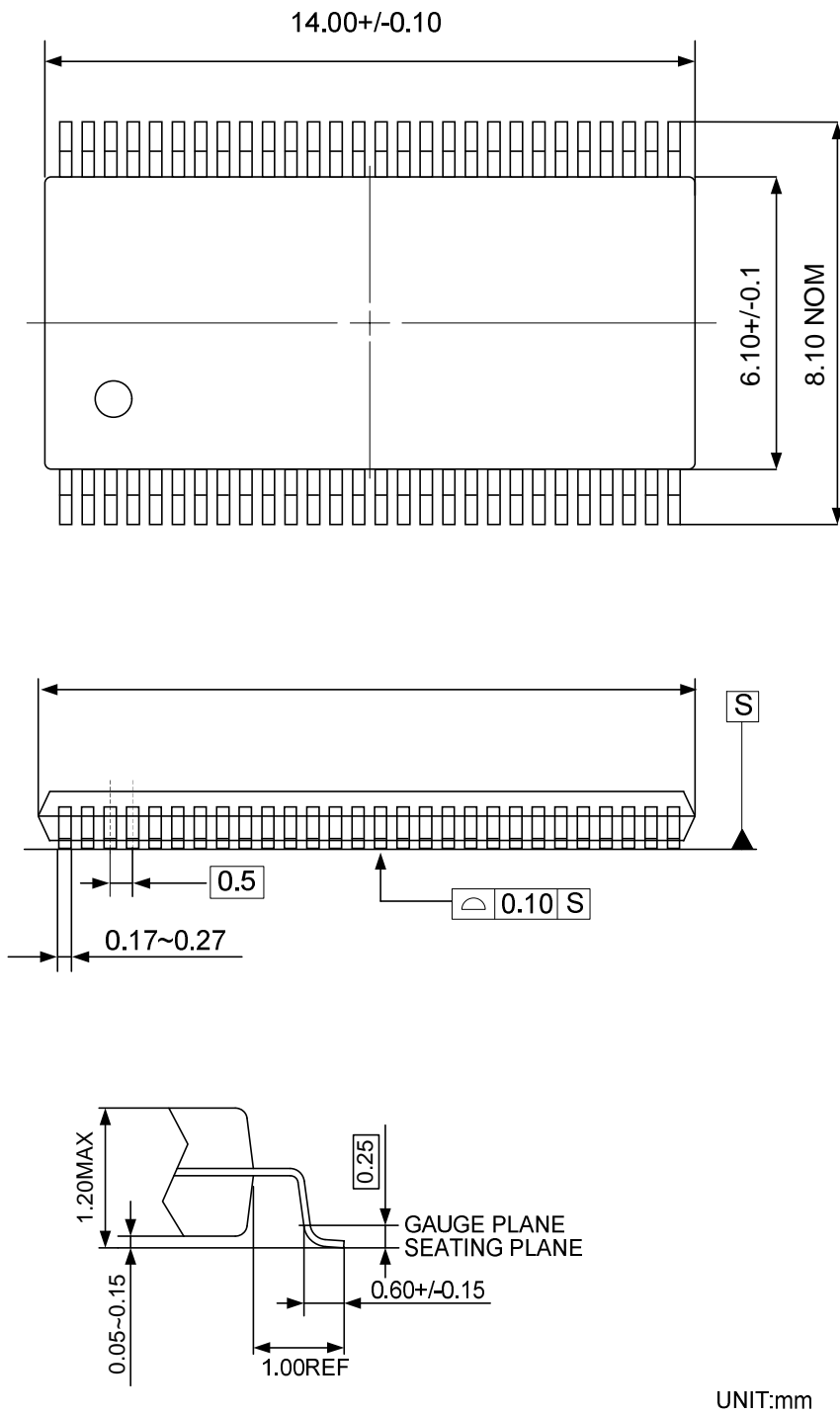
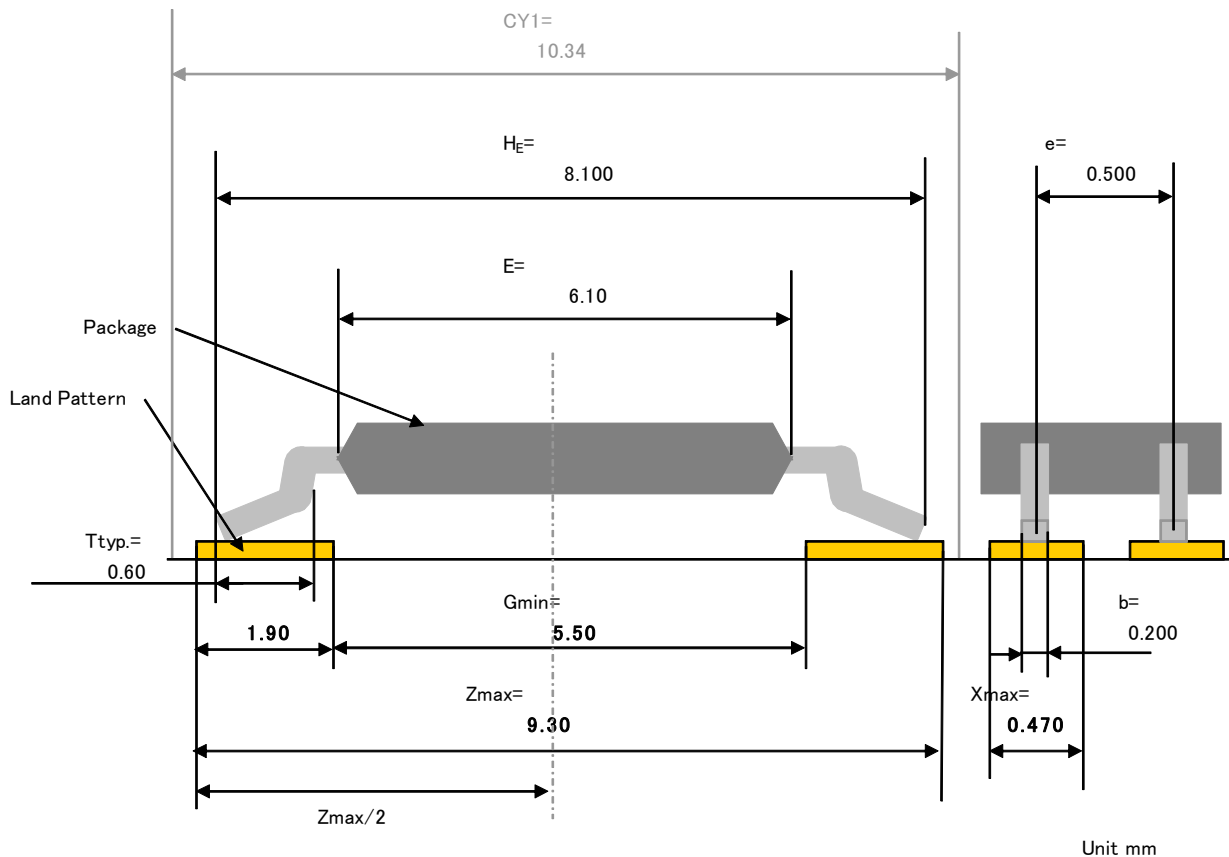

Figure 16. Package Diagram

Reference Land Pattern



**Figure 17. Reference of Land Pattern**

The recommendation mounting method of THine device is reflow soldering.  
 The reference pattern is using the calculation result on condition of reflow soldering.

Notes

This land pattern design is a calculated value based on JEITA ET-7501.  
 Please take into consideration in an actual substrate design about enough the ease of mounting, the intensity of connection, the density of mounting, and the solder paste used, etc... The optimal land pattern size changes with these parameters. Please use the value shown by the land pattern as reference data.



---

#### Notices and Requests

1. The product specifications described in this material are subject to change without prior notice.
2. The circuit diagrams described in this material are examples of the application which may not always apply to the customer's design. THine Electronics, Inc. ("THine") is not responsible for possible errors and omissions in this material. Please note even if errors or omissions should be found in this material, THine may not be able to correct them immediately.
3. This material contains THine's copyright, know-how or other proprietary. Copying or disclosing to third parties the contents of this material without THine's prior permission is prohibited.
4. Note that even if infringement of any third party's industrial ownership should occur by using this product, THine will be exempted from the responsibility unless it directly relates to the production process or functions of the product.
5. This product is not designed for applications that require extremely high-reliability/safety such as aerospace device, nuclear power control device, or medical device related to critical care, excluding when this product is specified for automotive use by THine and used it for that purpose. THine accepts no liability whatsoever for any damages, claims or losses arising out of the uses set forth above.
6. Despite our utmost efforts to improve the quality and reliability of the product, faults will occur with a certain small probability, which is inevitable to a semi-conductor product. Therefore, you are encouraged to have sufficiently redundant or error preventive design applied to the use of the product so as not to have our product cause any social or public damage.
7. Please note that this product is not designed to be radiation-proof.
8. Testing and other quality control techniques are used to this product to the extent THine deems necessary to support warranty for performance of this product. Except where mandated by applicable law or deemed necessary by THine based on the user's request, testing of all functions and performance of the product is not necessarily performed.
9. Customers are asked, if required, to judge by themselves if this product falls under the category of strategic goods under the Foreign Exchange and Foreign Trade Act.
10. The product or peripheral parts may be damaged by a surge in voltage over the absolute maximum ratings or malfunction, if pins of the product are shorted by such as foreign substance. The damages may cause a smoking and ignition. Therefore, you are encouraged to implement safety measures by adding protection devices, such as fuses.
11. This product is prohibited for the purpose of developing military modernization, including the development of weapons of mass destruction (WMD), and the purpose of violating human rights.

### ***THine Electronics, Inc.***

<https://www.thine.co.jp/>