

THCS252

20-bits GPIO or high speed Bus signal Transceiver

General description

The THCS252 integrates Serializer and Deserializer onto a single chip, which supports general purpose input and output (GPIO) signals through two pairs of differential signal.

GPIO sampling clock is selectable from external reference clock or internal oscillator clock.

The 8B10B encoding and decoding adopted by THCS252 is easy to connect to optical / wireless communication devices with high robustness and DC balanced signal.

The built-in adaptive equalizer enables flexible cable selection.

Application

The THCS252 can applicable to any systems which have many control signals between PCBs, for example Multi-function printers, Amusement machines, Factory Automation and TVs.

Features

- Support up to 20-bits GPIO
- Not required to input GPIO sampling clock in internal oscillator clock mode
- Full duplex communication by two pairs of differential signal
- Output buffer open-drain or push-pull selectable
- Support up to 8-bits low speed GPIO in low power Standby mode
- Integrated adaptive equalizer for long or lossy media
- 8B10B encoding and decoding
- Configurable digital noise filter
- Error detection and indication
- External reference clock frequency: 15-100MHz
- Spread Spectrum Clock Generator to reduce EMI
- Operating single power supply voltage: 1.7 V - 3.6 V
- Wide range IO voltage: 1.7V - 3.6V
- Operating ambient temperature: -40°C to 85°C

Block diagram

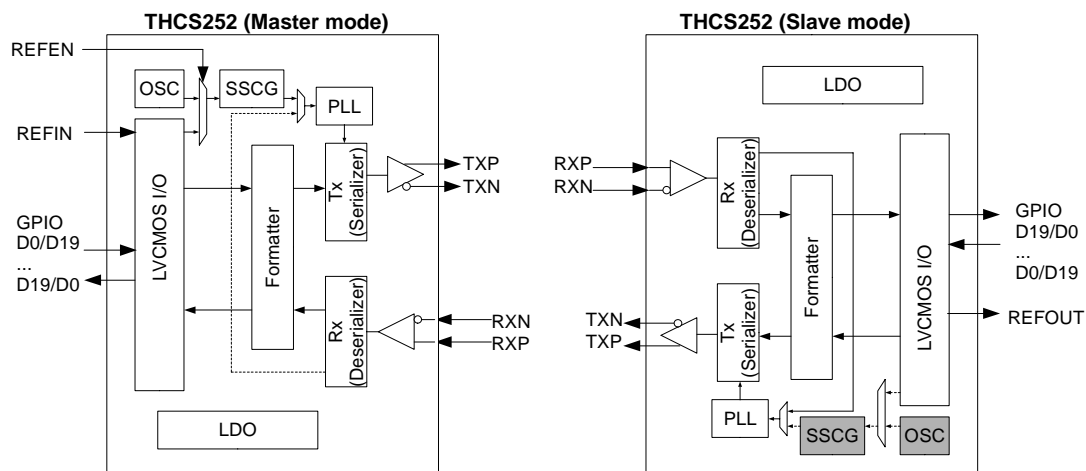

Contents page

General description.....	1
Application.....	1
Features.....	1
Block diagram.....	1
1. Pin configuration.....	3
2. Pin description.....	4
3. Absolute maximum ratings.....	7
4. Recommended operating conditions.....	7
5. Electrical characteristics.....	8
5.1. Current consumption.....	8
5.2. LVCMOS/Analog input DC specifications.....	9
5.3. LVCMOS AC characteristics.....	10
5.4. CML DC characteristics.....	13
5.5. CML AC characteristics.....	13
6. CML Line Eye diagrams.....	18
6.1. CML output Eye diagrams.....	18
6.2. CML input Eye diagrams.....	19
7. Function.....	20
7.1. Functional overview.....	20
7.2. Power supply.....	20
7.2.1. Internal regulator output/input function (CAPOUT, CAPINA, CAPINP).....	20
7.3. Operating mode.....	20
7.4. Transmission mode.....	21
7.4.1. Full duplex Bi-directional transmission mode.....	21
7.4.2. Unidirectional transmission mode.....	22
7.5. IO configuration.....	23
7.5.1. Input and Output digital noise filter.....	23
7.5.2. LVCMOS output buffer type configuration.....	23
7.5.3. 5V tolerant I/O.....	23
7.6. Sampling clock configuration.....	24
7.6.1. Sampling clock selection.....	24
7.6.2. Spread Spectrum Clock Generator (SSCG) and REFIN frequency.....	26
7.7. Error detection and indication.....	27
7.8. Standby mode.....	28
8. Package.....	29
Notices and Requests.....	30

1. Pin configuration

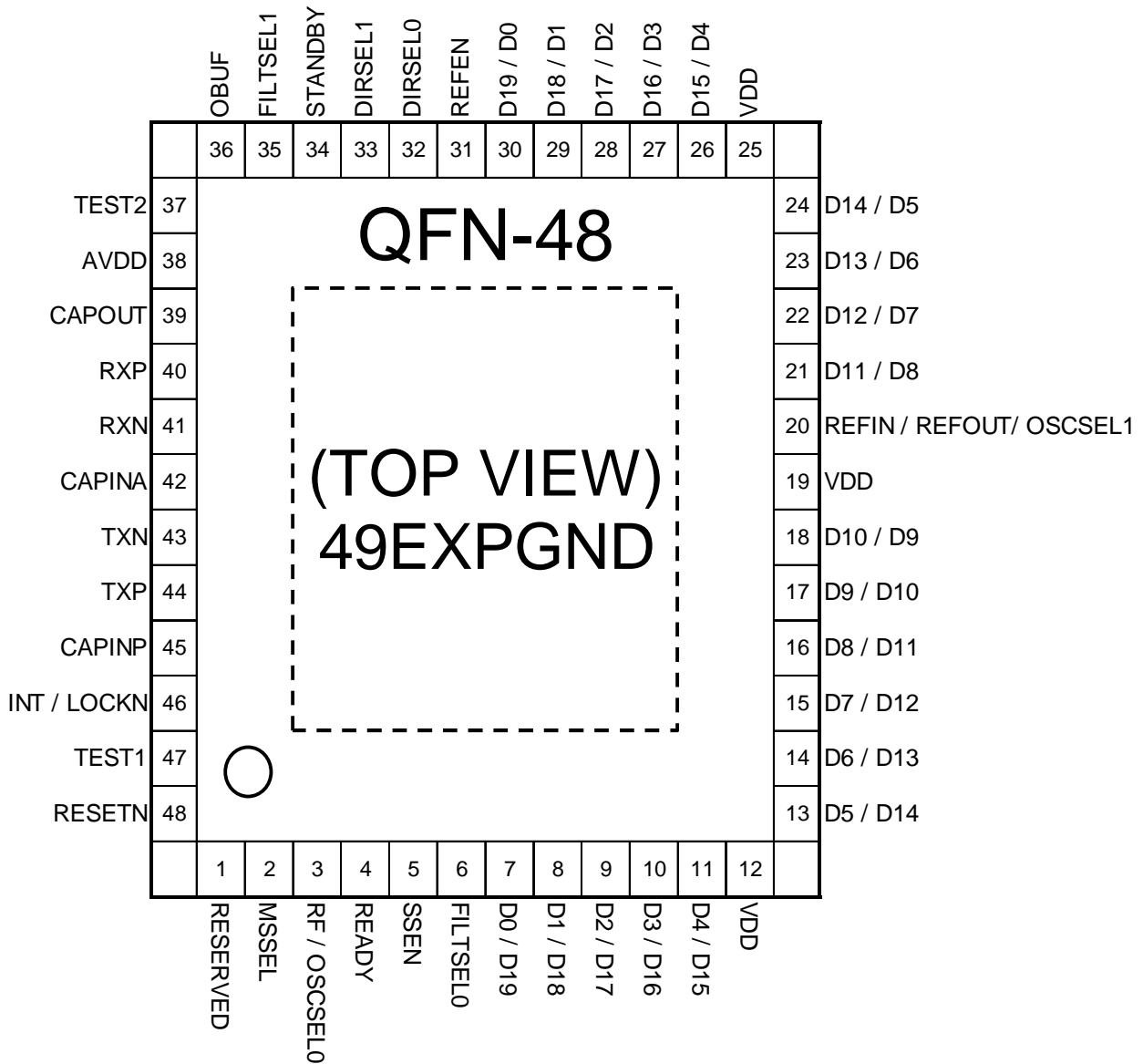

2. Pin description

Pin Name	Pin No.	Type	Description	Reference
TXP	44	CO	High-speed CML signal output	-
TXN	43	CO	High-speed CML signal output	-
RXP	40	CI	High-speed CML signal input	-
RXN	41	CI	High-speed CML signal input	-
RESETN	48	IL	Chip reset 0: Chip reset 1: Chip operation	-
STANDBY	34	IL	Standby mode entry 0: Normal mode operation 1: Standby mode operation	-
MSEL	2	IL	Master/Slave mode select 0: Master mode 1: Slave mode	-
FILTSEL1	35	IL	digital noise filter select	Table 5
DIRSEL0	32	IL	DIRSEL0: GPIO direction select	Table 2 Table 4
DIRSEL1	33	IL	DIRSEL1: GPIO direction select	Table 2 Table 4
OBUF	36	IL	Output buffer type select 0: open-drain 1: push-pull	-
REFEN	31	IL	Data sampling clock select (Master mode) 0: Internal oscillator clock 1: External reference clock	-
			CDR clock output enable (Slave mode) 0: REFOUT pin is Hi-Z state 1: CDR clock output from REFOUT pin	-
REFIN/ REFOUT/ OSCSEL1	20	B	REFIN: (Master mode) External Reference clock input	-
			REFOUT: (Slave mode) CDR clock output	-
			OSCSEL1: (Master mode) Oscillator clock frequency select	Table 9
			OSCSEL1: (Slave mode) Hi-Z	-
RF/ OSCSEL0	3	IL	RF: (Master mode) input clock edge select	Table 10
			RF: (Slave mode) output clock edge select	Figure 14
			OSCSEL0: (Master mode) Oscillator clock frequency select	Table 9
			OSCSEL0: (Slave mode) Set to Low	-
D0/ D19	7	BT	D0 (Master mode): Data input	-
			D19 (Slave mode): Data output	-

Pin Name	Pin No.	Type	Description	Reference
D1/ D18	8	BT	D1(Master mode): Data input D18(Slave mode): Data output	-
D2/ D17	9	BT	D2(Master mode): Data input D17(Slave mode): Data output	-
D3/ D16	10	BT	D3(Master mode): Data input D16(Slave mode): Data output	-
D4/ D15	11	B	D4(Master mode): Data input D15(Slave mode): Data output	-
D5/ D14	13	B	D5(Master mode): Data input D14(Slave mode): Data output	-
D6/ D13	14	B	D6(Master mode): Data input D13(Slave mode): Data output	-
D7/ D12	15	B	D7(Master mode): Data input D12(Slave mode): Data output	-
D8/ D11	16	B	D8(Master mode): Data input D11(Slave mode): Data output	-
D9/ D10	17	B	D9(Master mode): Data input D10(Slave mode): Data output	-
D10/ D9	18	B	D10(Master mode): Data input/output D9(Slave mode): Data input/output	-
D11/ D8	21	B	D11(Master mode): Data input/output D8(Slave mode): Data input/output	-
D12/ D7	22	B	D12(Master mode): Data input/output D7(Slave mode): Data input/output	-
D13/ D6	23	B	D13(Master mode): Data input/output D6(Slave mode): Data input/output	-
D14/ D5	24	B	D14(Master mode): Data input/output D5(Slave mode): Data input/output	-
D15/ D4	26	B	D15(Master mode): Data input/output D4(Slave mode): Data input/output	-
D16/ D3	27	BT	D16(Master mode): Data input/output D3(Slave mode): Data input/output	-
D17/ D2	28	BT	D17(Master mode): Data input/output D2(Slave mode): Data output	-
D18/ D1	29	BT	D18(Master mode): Data output D1(Slave mode): Data input	-
D19/ D0	30	BT	D19(Master mode): Data input/output D0(Slave mode): Data input/output	-
SSEN	5	BL	SSEN(Master mode): SSCG PLL enable 0: SSCG PLL is disabled 1: SSCG PLL is enabled SSEN(Slave mode): Set to Low	-
FILTSEL0	6	BL	FILTSEL0: digital noise filter select	Table 5
INT/ LOCKN	46	BO	INT: Interrupt output when READY=1 0: Error occurred 1(pull-up): No Error	-

Pin Name	Pin No.	Type	Description	Reference
			LOCKN(Master mode): Lock detect input 0: Lock state 1(pull-up): Unlock state	-
			LOCKN(Slave mode): Lock detect output 0: Lock state 1(pull-up): Unlock state	-
READY	4	B	CML Link communication status 0: Unlock state 1: Lock state	-
TEST1	47	IL	TEST1 shall be tied to Ground.	-
TEST2	37	AI	TEST2 shall be tied to Ground.	-
CAPOUT	39	PWR	Decoupling capacitor Pin, 1.2V output.	Figure 9
CAPINA	42	PWR	1.2V Analog power supply input.	Figure 9
CAPINP	45	PWR	1.2V Analog power supply input.	Figure 9
VDD	12 19 25	PWR	1.7-3.6V Digital power supply input for LVC MOS I/O.	-
AVDD	38	PWR	1.7-3.6V Analog power supply input for on-chip regulator.	Figure 9
EXPGND	49	GND	Exposed Pad Ground. Must be tied to the PCB ground plane through an array of vias.	-

Pin Type definition

Analog Buffer

CO : CML Output buffer

CI : CML Input buffer

AI : Analog Input buffer

LVC MOS buffer

IL : Low speed schmitt trigger LVC MOS Input buffer

B : LVC MOS Bi-directional buffer

BO : Open-drain LVC MOS Bi-directional buffer

BL : Low speed 5V tolerant schmitt trigger LVC MOS Bi-directional buffer

BT : Low speed 5V tolerant LVC MOS Bi-directional buffer

Power/Ground

PWR : Power supply

GND : Ground

3. Absolute maximum ratings

Parameter	Min	Typ	Max	Unit
Supply voltage(VDD,AVDD)	-0.3	-	4.0	V
LVC MOS input voltage	-0.3	-	VDD+0.3	V
LVC MOS output voltage	-0.3	-	VDD+0.3	V
5V tolerant Bi-directional buffer input voltage	-0.3	-	VDD+2.5	V
5V tolerant Bi-directional buffer output voltage	-0.3	-	VDD+2.5	V
Open-drain output voltage	-0.3	-	4.0	V
CML receiver input voltage	-0.3	-	CAPINA+0.3	V
CML transmitter output voltage	-0.3	-	CAPINP+0.3	V
Output current	-50	-	50	mA
Storage temperature	-55	-	125	°C
Junction temperature	-	-	125	°C
Reflow peak temperature/time	-	-	260/10	°C/sec
Theta-ja (Junction-to-Ambient)	30.8 [*1]			°C/W
Psi-jt (Junction-to-Top of Package)	2.8 [*1]			°C/W
Maximum power dissipation @+25°C	3.2 [*1]			W

“Absolute maximum ratings” are those values beyond which the safety of the device cannot be guaranteed.

They are not meant to imply that the device should be operated at these limits. The tables of “Electrical Characteristics” specify conditions for device operation.

*1: Thermal parameters are not guaranteed value. This value assists board and system level designers

4. Recommended operating conditions

Parameter	Min	Typ	Max	Unit
Supply voltage(VDD,AVDD)	1.7	-	3.6	V
Operating ambient temperature	-40	-	85	°C

VDD and AVDD supply voltage shall be the same voltage.

5. Electrical characteristics

5.1. Current consumption

Symbol	Parameter	Pin Type	Condition	Min	Typ	Max	Unit
Idd_w1	Normal mode current Low current use case [*1]	PWR	AVDD=3.3V VDD=3.3V	-	80	-	mA
Idd_w2	Normal mode current High current use case [*2]	PWR	AVDD=3.3V VDD=3.3V	-	300	-	mA
Idda_stby	Standby mode current	PWR	AVDD=3.3V VDD=3.3V	-	4	-	mA
Idda_slp	Sleep mode current	PWR	AVDD=3.3V VDD=3.3V	-	3	-	mA
Idda_rst	Reset mode current	PWR	AVDD=3.3V VDD=3.3V	-	3	-	mA

PWR : Power supply

*1: Master mode of Unidirectional transmission mode, 20-bits GPIO input, 100MHz of REFIN clock

*2: Slave mode of Unidirectional transmission mode, 20-bits GPIO output, 100MHz of REFOUT clock

5.2. LVC MOS/Analog input DC specifications

Symbol	Parameter	Pin Type	Condition	Min	Typ	Max	Unit
VIH	High level input voltage	B,BT, BO	$1.7V \leq VDD < 2.0V$	0.65 VDD	-	VDD	V
			$2.0V \leq VDD < 3.0V$	0.70 VDD	-	VDD	V
			$3.0V \leq VDD \leq 3.6V$	2.0	-	VDD	V
		IL,BL	$1.7V \leq VDD \leq 3.6V$	0.70 VDD	-	VDD	V
VIL	Low level input voltage	B,BT, BO	$1.7V \leq VDD < 2.0V$	0	-	0.35 VDD	V
			$2.0V \leq VDD < 3.0V$	0	-	0.30 VDD	V
			$3.0V \leq VDD \leq 3.6V$	0	-	0.8	V
		IL,BL	$1.7V \leq VDD \leq 3.6V$	0	-	0.30 VDD	V
		AI	$1.7V \leq VDD \leq 3.6V$	0	-	0.15 VDD	V
VOH	High level output voltage	B,BT, BL	$1.7V \leq VDD < 2.0V$ IOH=-2mA	VDD - 0.30	-	VDD	V
			$2.0V \leq VDD \leq 3.6V$ IOH=-4mA	VDD - 0.45	-	VDD	V
VOL	Low level output voltage [*1]	B,BT, BL	$1.7V \leq VDD < 2.0V$ IOL=2mA	0	-	0.30	V
			$2.0V \leq VDD \leq 3.6V$ IOL=4mA	0	-	0.45	V
		BO	$1.7V \leq VDD \leq 3.6V$ IOL=2mA	0	-	0.27	V
I IH	Input leak current high	IL	VIN=VDD	-10	-	10	uA
I IL	Input leak current low	IL	VIN=0V	-10	-	10	uA
IOZH	Output leak current high in Hi-Z state	B,BT, BL,BO	VIN=VDD	-10	-	10	uA
IOZL	Output leak current low in Hi-Z state	B,BT, BL,BO	VIN=0V	-10	-	10	uA

AI : Analog Input buffer

IL : Low speed schmitt trigger LVC MOS Input buffer

B : LVC MOS Bi-directional buffer

BO : Open-drain LVC MOS Bi-directional buffer

BL : Low speed 5V tolerant schmitt trigger LVC MOS Bi-directional buffer

BT : Low speed 5V tolerant LVC MOS Bi-directional buffer

5.3. LVC MOS AC characteristics

Symbol	Parameter	Condition		Min	Typ	Max	Unit
tRSN	RESETN low time	-		3	-	-	us
tTCIP	REFIN period	-		10	-	66.6	ns
tTCH	REFIN high time	-		0.35 tTCIP	0.5 tTCIP	0.65 tTCIP	ns
tTCL	REFIN low time	-		0.35 tTCIP	0.5 tTCIP	0.65 tTCIP	ns
tTS	Data input setup to REFIN	Pin type: B	$1.7V \leq VDD \leq 3.6V$	2.0	-	-	ns
		Pin type: BT	$1.7V \leq VDD < 2.25V$	25	-	-	ns
			$2.25V \leq VDD \leq 2.75V$	2.5	-	-	ns
			$2.75V < VDD \leq 3.6V$	2.0	-	-	ns
tTH	Data input hold to REFIN	-		1.0	-	-	ns
tTPD	Power on to RESETN high delay	-		0	-	-	ns
tOSC	Internal oscillator clock period	OSCSEL1=0 OSCSEL0=0		41.67	50	62.5	ns
		OSCSEL1=1 OSCSEL0=0		20.84	25	31.25	ns
		OSCSEL1=1 OSCSEL0=1		10.42	12.5	15.62	ns
tDCP	Data sampling clock period	REFEN=0		-	tOSC	-	ns
		REFEN=1		-	tTCIP	-	ns
tFLTCK	Noise filter clock period	REFEN=0		10.42	12.5	15.62	ns
		REFEN=1		-	tTCIP	-	ns
tTCD	Input data to output data delay (Master mode to Slave mode)	SSEN=0	FILTSEL1=0 FILTSEL0=0	12 tDCP	-	25 tDCP	ns
			FILTSEL1=0 FILTSEL0=1	19 tDCP	-	35 tDCP	ns
			FILTSEL1=1 FILTSEL0=0	24 tDCP	-	43 tDCP	ns
			FILTSEL1=1 FILTSEL0=1	34 tDCP	-	59 tDCP	ns
		SSEN=1	FILTSEL1=0 FILTSEL0=0	57 tDCP	-	110 tDCP	ns
			FILTSEL1=0 FILTSEL0=1	64 tDCP	-	120 tDCP	ns
			FILTSEL1=1 FILTSEL0=0	69 tDCP	-	128 tDCP	ns
			FILTSEL1=1 FILTSEL0=1	79 tDCP	-	144 tDCP	ns
tRCP	REFOUT period	-		-	tDCP	-	ns
tRCH	REFOUT high time	-		-	0.5 tDCP	-	ns
tRCL	REFOUT low time	-		-	0.5 tDCP	-	ns
tDOUT	Data output period	-		-	tDCP	-	ns
tRS	Data output setup to REFOUT	-		0.45 tDCP - 0.675	-	-	ns
tRH	Data output hold to REFOUT	-		0.45 tDCP - 2.175	-	-	ns
tRCD	Input data to output data delay (Slave mode to Master mode)	FILTSEL1=0 FILTSEL0=0		12 tDCP	-	25 tDCP	ns
		FILTSEL1=0 FILTSEL0=1		19 tDCP	-	35 tDCP	ns
		FILTSEL1=1 FILTSEL0=0		24 tDCP	-	43 tDCP	ns
		FILTSEL1=1 FILTSEL0=1		34 tDCP	-	59 tDCP	ns
tRRDY	RESETN high to READY high delay	-		0	-	10	ms

Symbol	Parameter	Condition	Min	Typ	Max	Unit
tNRDY	STANDBY low to READY high delay	-	0	-	10	ms
tSRDY	STANDBY high to READY high delay	-	0	-	10	ms
tSSKW	STANDBY high of Master mode and Slave mode skew margin	-	-400	-	+400	us
tTLH	Clock and Data output low to high transition time	Clock	-	-	2.1	ns
		Data(Pin type=B)	-	-	4.2	ns
		Data(Pin type=BT)	-	-	5.9	ns
tTHL	Clock and data output high to low transition time	Clock	-	-	2.1	ns
		Data(Pin type=B)	-	-	4.3	ns
		Data(Pin type=BT)	-	-	6.1	ns

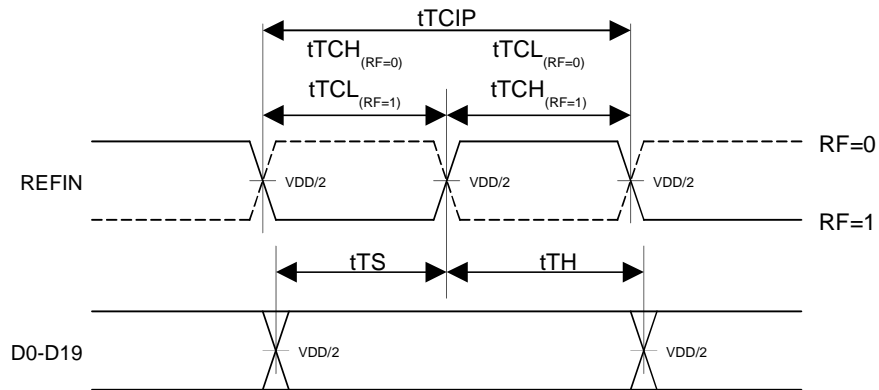

Figure 1 LVC MOS input timing diagram

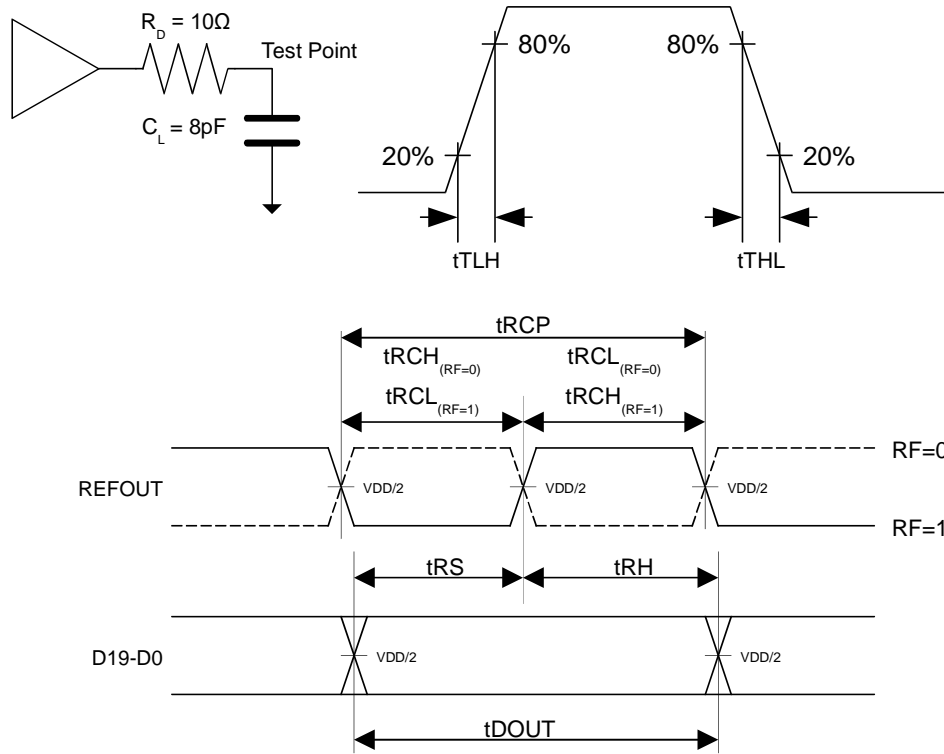

Figure 2 LVC MOS output timing diagram

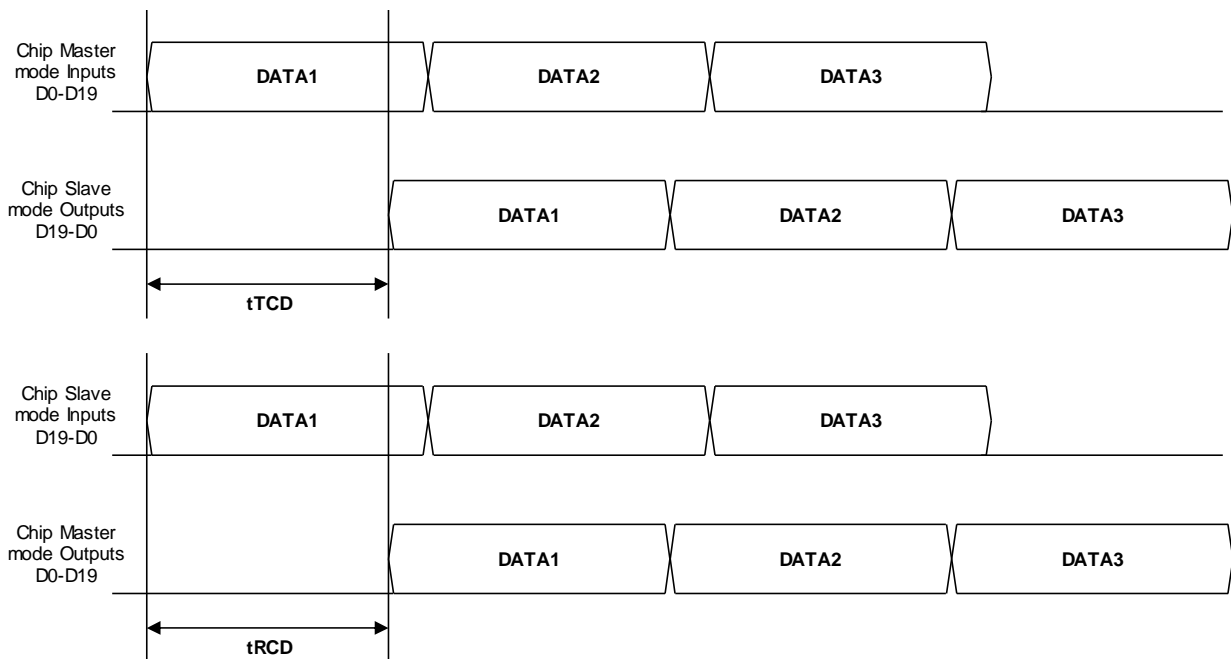

Figure 3 GPIO Input to Output delay timing diagram

5.4. CML DC characteristics

Symbol	Parameter	Condition	Min	Typ	Max	Unit
VTOD	CML differential output peak to peak signal	-	600	800	1000	mVpp
VTOC	CML common mode output voltage	-	-	1200 - 0.5 VTOD	-	mV
ITOH	CML output leak current high	RESETN=0 TXP/N=CAPINA	-30	-	30	uA
ITOS	CML output short current	RESETN=0 TXP/N=0V	-80	-	-	mA
VRTH	CML differential input high threshold	-	-	-	50	mV
VRTL	CML differential input low threshold	-	-50	-	-	mV
IRIH	CML input leak current high	RESETN=0 RXP/N=CAPINA	-10	-	10	uA
IRIL	CML input leak current low	RESETN=0 RXP/N=0V	-10	-	10	uA
IRRIH	CML input current high	RXP/N=CAPINA	-	-	2	mA
IRRIL	CML input current low	RXP/N=0V	-6	-	-	mA
RRIN	CML differential input resistance	-	80	100	120	Ω

5.5. CML AC characteristics

Symbol	Parameter	Condition	Min	Typ	Max	Unit
tTRF	CML output rise and fall time (20%-80%)	-	50	-	150	ps
tPLL0	RESETN=1 to CML output delay	-	-	-	10	ms
tPLL1	RESETN=0 to CML output high fix delay	-	-	-	500	ns
tTNP0	READY low to training pattern output delay	-	-	-	100	us
tTBIT	Output unit interval	-	-	tDCP÷30	-	ns
tRBIT	Input unit interval	-	250	-	2222	ps
tRPLL0	Training pattern input to LOCKN low delay	Unidirectional mode	-	-	10	ms
tRPLL1	RESETN low to LOCKN High delay	Unidirectional mode	-	-	10	us
tRLCK0	LOCKN low to data output delay	Unidirectional mode	-	-	5	ms

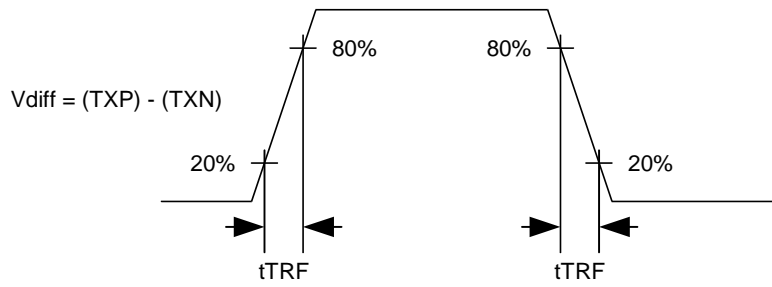
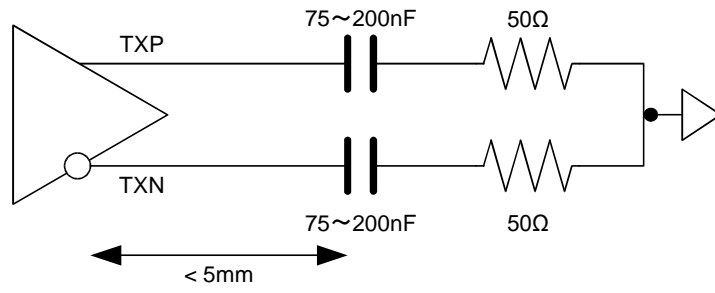

Figure 4 CML output AC characteristics diagram

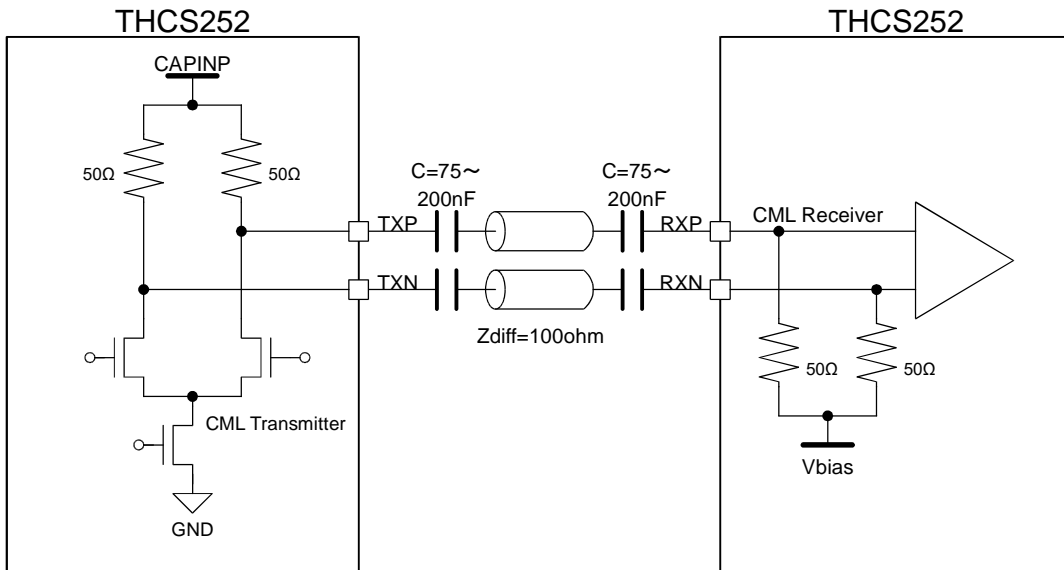

Figure 5 CML buffer equivalent circuit

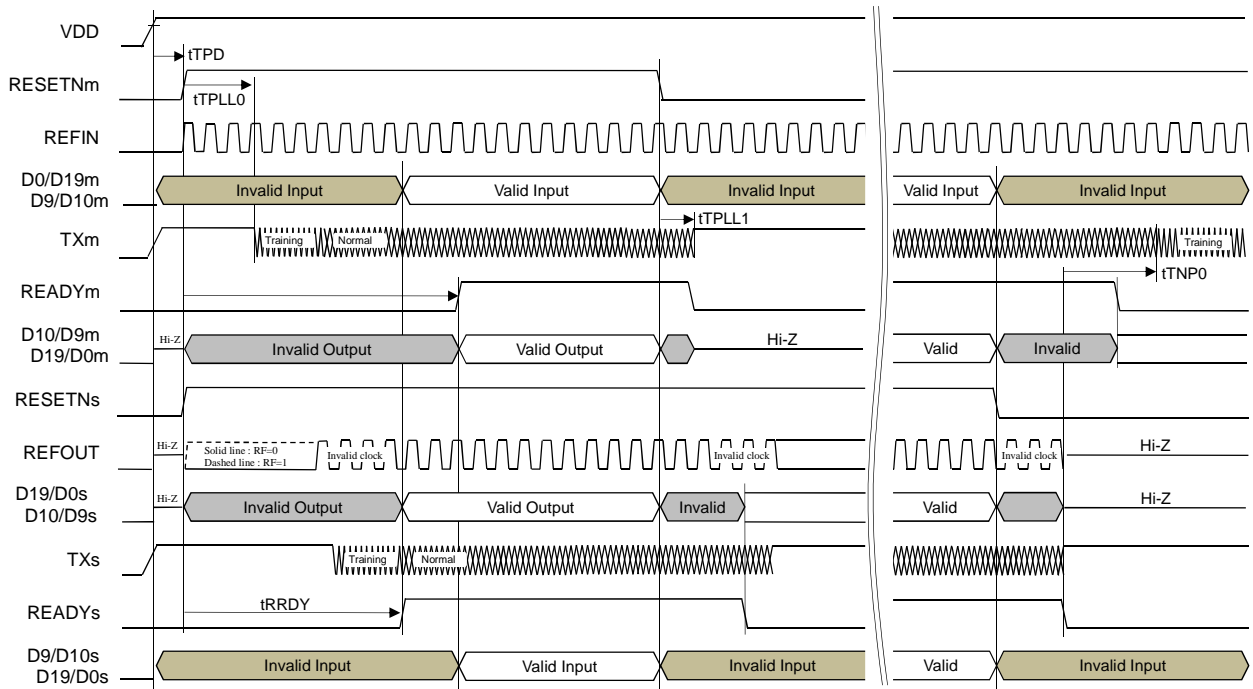
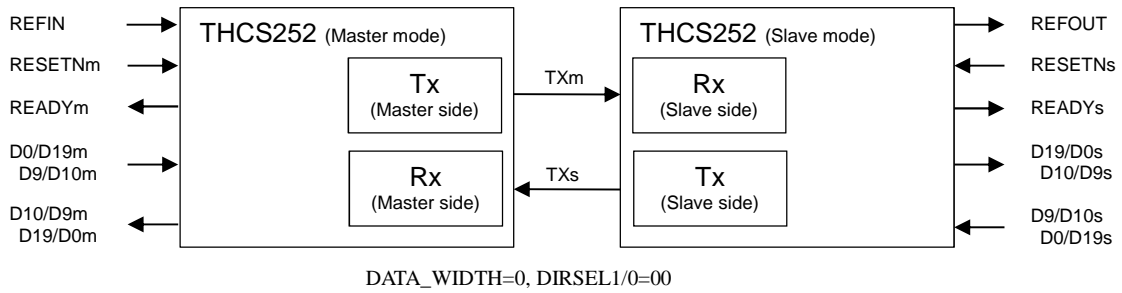

Figure 6 GPIO/CML Bi-directional mode Power on & Reset timing diagram

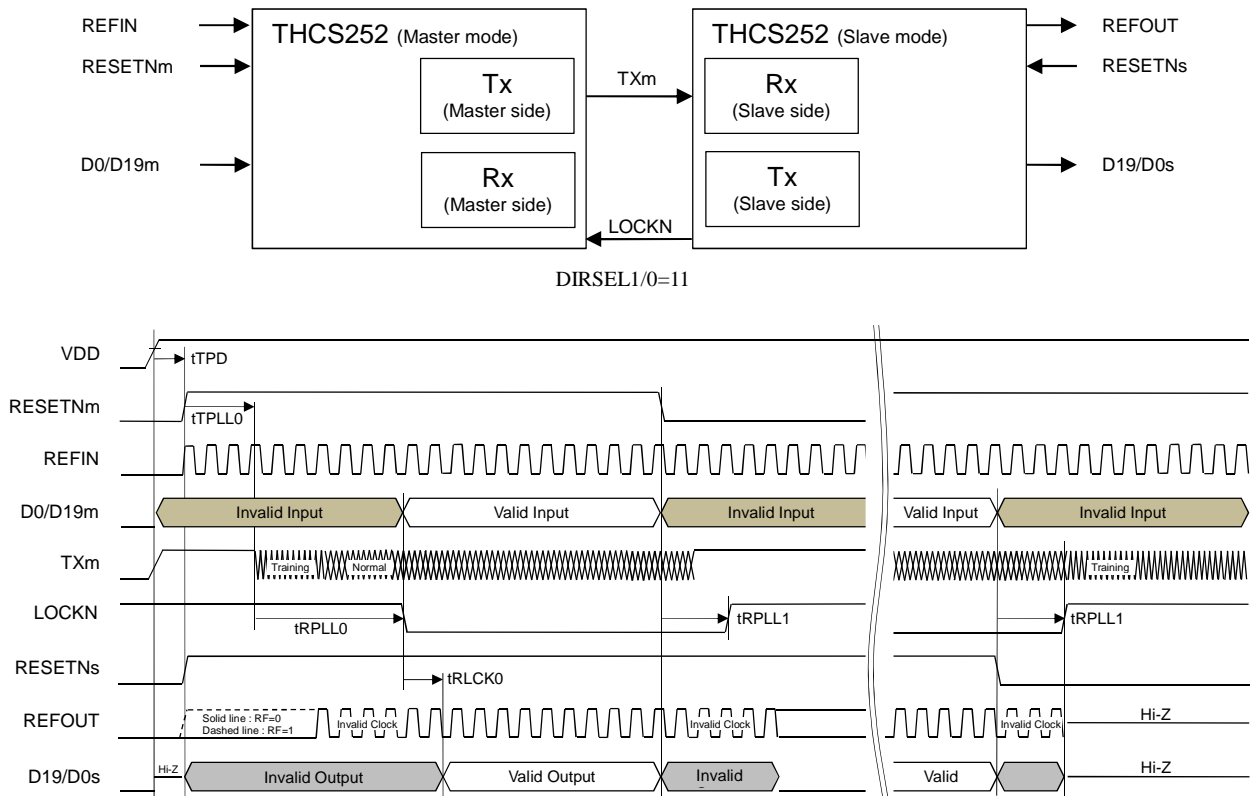

Figure 7 GPIO/CML Unidirectional mode lock & unlock timing diagram

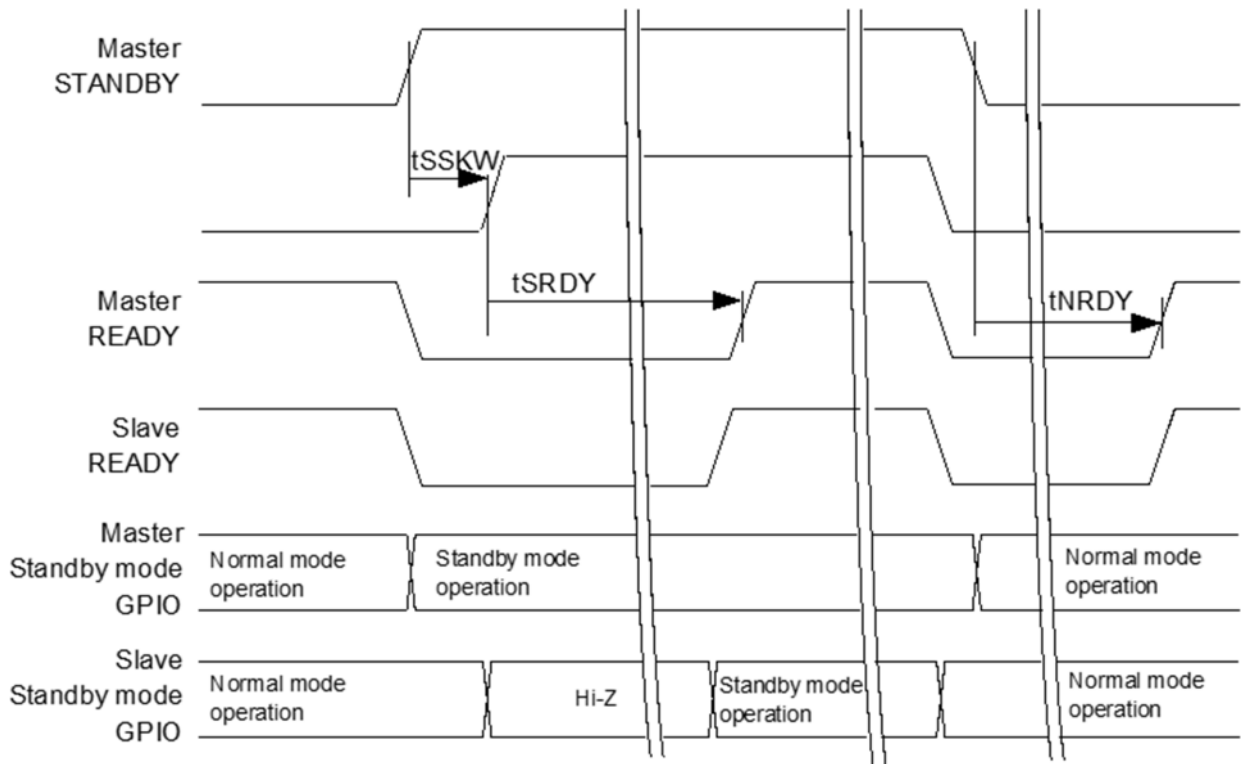
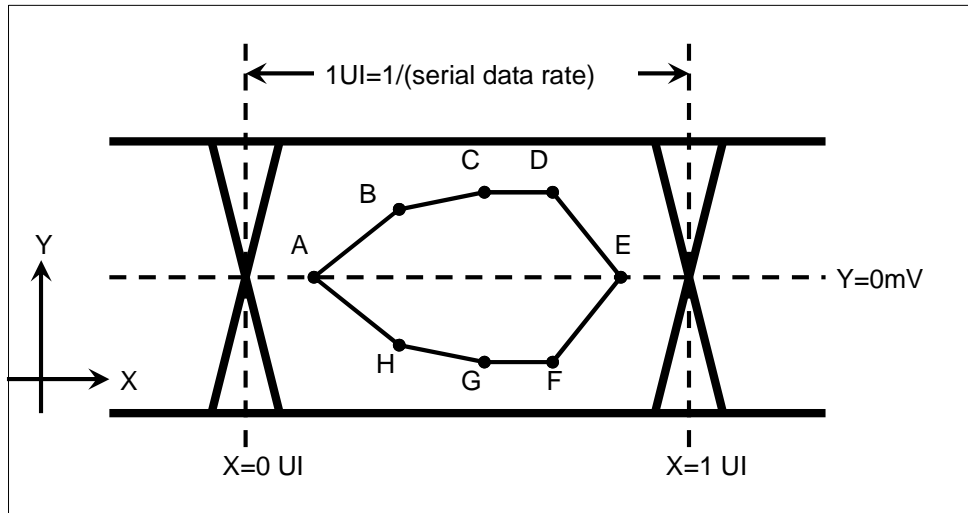

Figure 8 Standby mode timing diagram

6. CML Line Eye diagrams

6.1. CML output Eye diagrams



	X[UI]	Y[mV]
A	0.15	0
B	0.355	140
C	0.5	175
D	0.645	175
E	0.85	0
F	0.645	-175
G	0.5	-175
H	0.355	-140

6.2. CML input Eye diagrams

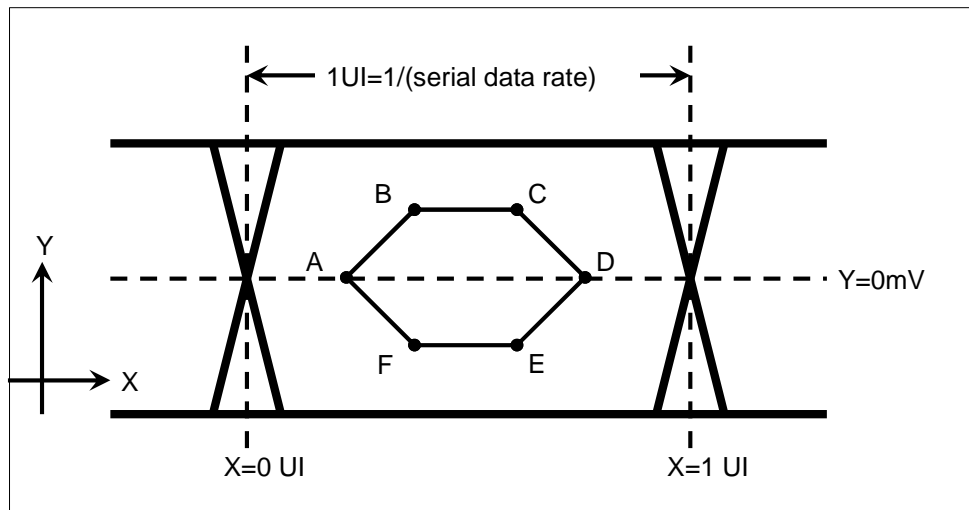

	X[UI]	Y[mV]
A	0.25	0
B	0.3	50
C	0.7	50
D	0.75	0
E	0.7	-50
F	0.3	-50

7. Function

7.1. Functional overview

With high speed CML Serializer and Deserializer integrated onto a single chip, THCS252 enables Aggregation/Deaggregation up to 20-bits parallel General-Purpose I/O (GPIO) signal through full-duplex communication by two pairs of differential signal with minimal external components. THCS252 supports up to 8-bits low speed GPIO signal in low power Standby mode. It does not require any external clock generators e.g. a crystal oscillator. A pair of THCS252 enables to monitor and control peripheral devices via GPIOs. In case communication errors occur, they keep the GPIO signals and report by an interrupt signal.

7.2. Power supply

7.2.1. Internal regulator output/input function (CAPOUT, CAPINA, CAPINP)

An internal regulator produces 1.2V (CAPOUT) only for internal use. It shall not be used for any other external loads. Bypass CAPOUT to GND with 10uF as a power supply pin. Bypass AVDD to GND with >10uF. CAPINP and CAPINA supply reference voltage for internal analog circuits. Bypass CAPINP/CAPINA to GND with 0.1uF as power supply pins to reduce high frequency noise. CAPOUT, CAPINA and CAPINP must be tied together as Figure 9.

It is recommended to place ferrite bead for AVDD pins to reduce noise as Figure 9.

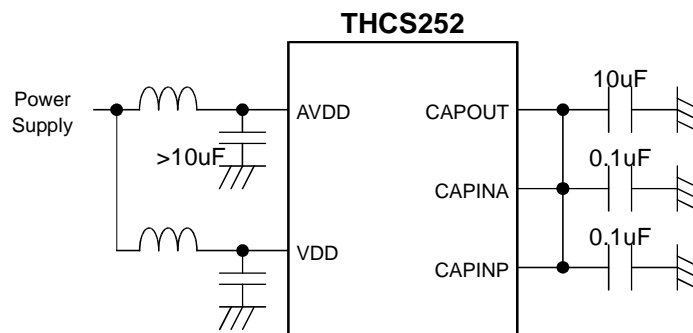

Figure 9 Connection of CAPOUT, CAPINA, CAPINP and decoupling capacitor

7.3. Operating mode

Table 1 shows operating mode setting.

Table 1 Operating mode setting

Operating mode	Setting		description
	RESETN	STANDBY	
Reset	0	-	Chip reset All outputs are Hi-Z
Normal	1	0	Normal operating mode
Standby	1	1	Low power and low frequency sampling rate transmission through up to 8-bits GPIO.

7.4. Transmission mode

THCS252 has a Bi-directional transmission mode with full-duplex communication and a Unidirectional communication mode.

7.4.1. Full duplex Bi-directional transmission mode

THCS252 can be used a pair of Master mode and Slave mode. Master mode samples data by external reference clock or internal oscillator clock. Slave mode samples data by CDR (Clock Data Recovery) clock generated by Rx. Same configuration of MSSEL between Master mode and Slave mode is prohibited. See Figure 10.

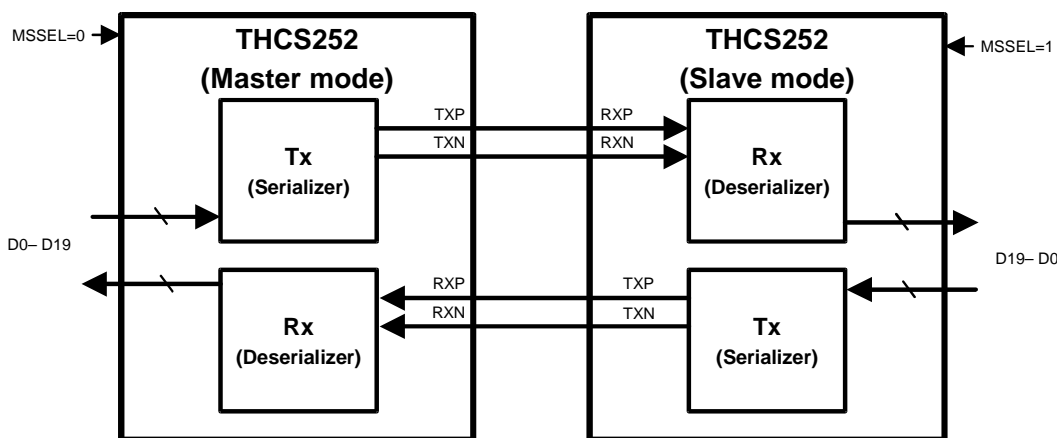

Figure 10 Setting for Bi-directional transmission mode

Table 2 Common setting of Master/Slave mode for Full duplex mode

Use case	A-1	A-2	A-3
Setting			
DIRSEL1, DIRSEL0	00	01	10
Mode			
Downstream bit count	10	14	18
Upstream bit count	10	6	2
CML line data rate	External reference clock mode: 1/TCIP x 30 Internal oscillator clock mode: 1/IOSC x 30		
Data pin for Master mode			
D0/D19	=>	=>	=>
D1/D18	=>	=>	=>
D2/D17	=>	=>	=>
D3/D16	=>	=>	=>
D4/D15	=>	=>	=>
D5/D14	=>	=>	=>
D6/D13	=>	=>	=>
D7/D12	=>	=>	=>
D8/D11	=>	=>	=>
D9/D10	=>	=>	=>
D10/D9	<=	=>	=>
D11/D8	<=	=>	=>
D12/D7	<=	=>	=>
D13/D6	<=	=>	=>
D14/D5	<=	<=	=>
D15/D4	<=	<=	=>
D16/D3	<=	<=	=>
D17/D2	<=	<=	=>
D18/D1	<=	<=	<=
D19/D0	<=	<=	<=
Data pin for Slave mode			
D19/D0			
D18/D1			
D17/D2			
D16/D3			
D15/D4			
D14/D5			
D13/D6			
D12/D7			
D11/D8			
D10/D9			
D9/D10			
D8/D11			
D7/D12			
D6/D13			
D5/D14			
D4/D15			
D3/D16			
D2/D17			
D1/D18			
D0/D19			

"=>" means Downstream (GPIO input in Master mode and GPIO output in Slave mode).

"<=" means Upstream (GPIO input in Slave mode and GPIO output in Master mode).

Start communication after setting each "Use case" in both Master/Slave.

7.4.2. Unidirectional transmission mode

THCS252 operates in Unidirectional transmission mode by setting DIRSEL1=1 and DIRSEL0=1. A pair of differential signal from Slave mode to Master mode shall not be connected. LOCKN connection from Slave mode to Master mode is required.

Table 3 INT/LOCKN function in Unidirectional transmission mode

Setting			LOCKN	Description
DIRSEL1	DIRSEL0	MSEL		
1	1	0	LOCKN Input	Master mode
		1	LOCKN Output (open-drain)	Slave mode

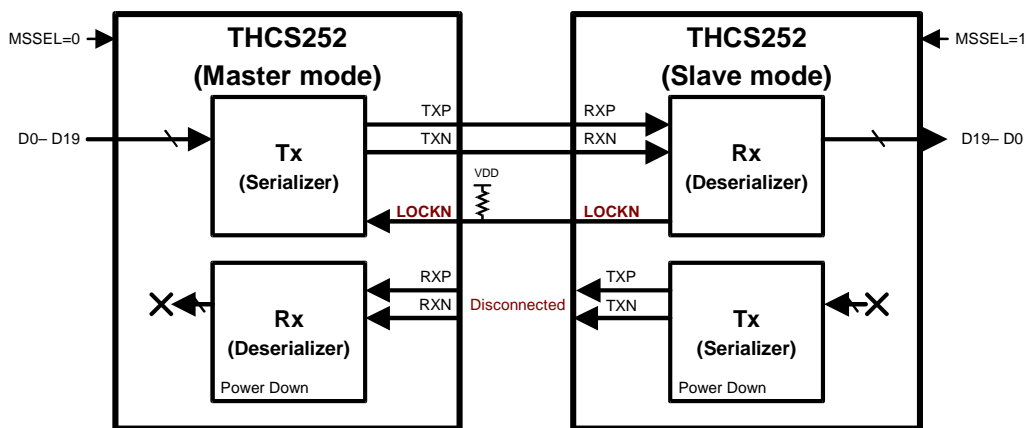

Figure 11 Setting for Unidirectional transmission mode

Table 4 Common setting of Master/Slave mode for Unidirectional transmission mode

Use case		U-1		
Mode	Downstream bit count	20		
	Upstream bit count	0		
	CML line data rate	External reference clock mode: 1/tTCIP x 30 Internal oscillator clock mode: 1/tOSC x 30		
Data pin for Master mode	D0/D19 D19/D0	=>	D19/D0 D0/D19	Data pin for Slave mode

"=>" means Downstream (GPIO input in Master mode and GPIO output in Slave mode).

Start communication after setting each "Use case" in both Master/Slave.

7.5. IO configuration

7.5.1. Input and Output digital noise filter

THCS252 has digital noise filters for GPIO input (for CMOS input noise immunity) and output (for CML Line noise immunity) which are configured by setting FILTSEL1 and FILTSEL0 shown in Table 5 and Table 6. The data width less than (tap_num - 1) tFLTCK is filtered. tap_num is shown in Table 5, Table 6.

Table 5 Input digital noise filter setting

FILTSEL1	FILTSEL0	Function	Filter number of taps (tap_num)
0	0	All digital noise filter setting	Disable
	1		4
1	0		8
	1		16

Table 6 Output digital noise filter setting

FILTSEL1	FILTSEL0	Function	Filter number of taps (tap_num)
0	0	All digital noise filter setting	Disable
	1		4
1	0		8
	1		16

7.5.2. LVCMOS output buffer type configuration

GPIO output buffer types are selectable from open-drain or push-pull by setting OBUF.

Table 7 Output buffer type configuration

Setting OBUF	Function
0	All GPIO outputs buffer type are selected to open-drain.
1	All GPIO outputs buffer type are selected to push-pull.

7.5.3. 5V tolerant I/O

Figure 12 shows the 5V tolerant I/O. Master and Slave has eight 5V tolerant I/O each.

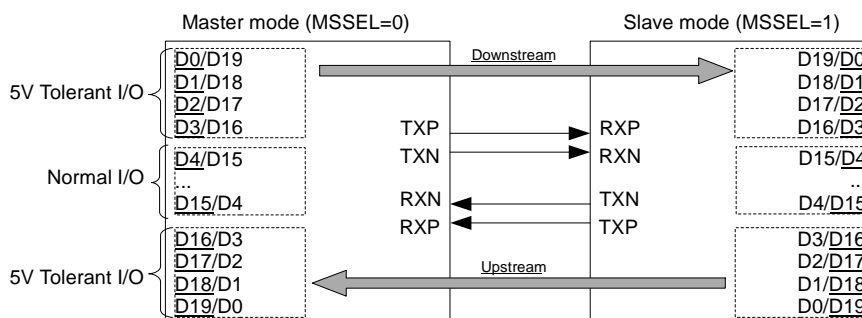

Figure 12 5V tolerant I/O

7.6. Sampling clock configuration

7.6.1. Sampling clock selection

GPIO sampling clock is always supplied from the Master mode and Master mode is selectable from internal oscillator clock or external reference clock input as shown in Figure 13 and Table 8. Internal oscillator frequency is selectable from 20MHz, 40MHz or 80MHz. Table 9 shows internal oscillator frequency and CML Line data rate. REFEN of Master mode and Slave mode shall be the same setting. GPIO data sampling clock of Slave mode is CDR clock from Rx.

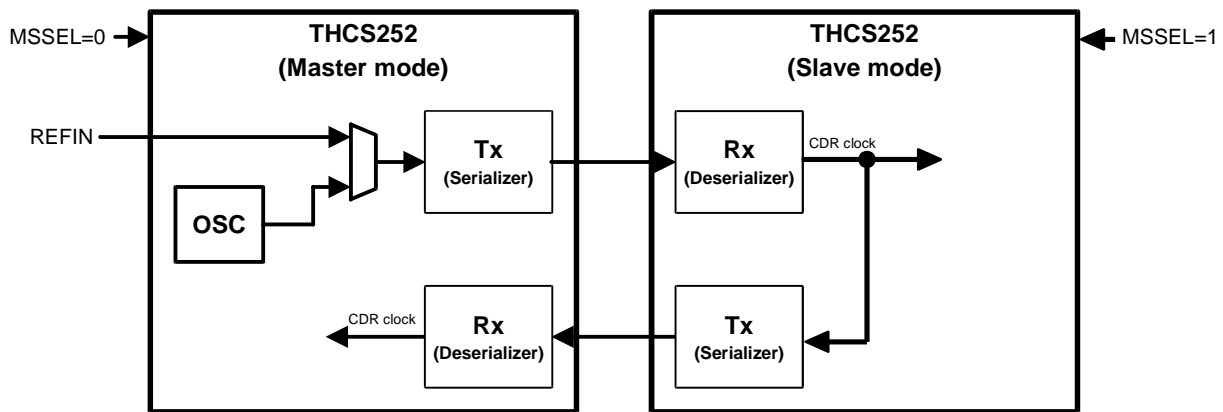

Figure 13 GPIO sampling clock source

Table 8 Sampling clock and REFEN/REFOUT/OSCSEL1 and RF/OSCSEL0 function

Setting		Sampling clock	REFIN/REFOUT/OSCSEL1	RF/OSCSEL0	Description
REFEN	MSEL				
0	0 (Master mode)	Internal oscillator clock	Internal oscillator clock setting OSCSEL1, OSCSEL0		GPIO inputs are sampled by internal oscillator clock. Internal oscillator clock frequency is selected by setting of OSCSEL1 and OSCSEL0 (See Table 9)
	1 (Slave mode)	CDR clock	Hi-Z	(Set to Low)	-
1	0 (Master mode)	External reference clock	External reference clock input REFIN	Sampling clock edge selection RF	GPIO inputs are sampled by external reference clock
	1 (Slave mode)	CDR clock	CDR clock output REFOUT	GPIO output clock edge selection RF	CDR clock output

Table 9 Oscillator Clock Frequency and CML Line data rate

Setting				Sampling frequency [*1]	CML Line data rate[*1]	Description
REFEN	MSEL	OSCSEL1	OSCSEL0			
0	0 (Master mode)	0	0	20MHz	600Mbps	-
		0	1	-	-	Prohibition
		1	0	40MHz	1.2Gbps	-
		1	1	80MHz	2.4Gbps	-

*1 Typical value, Spec is typical±20%

When REFEN=1, RF selects REFIN sampling clock edge of Master mode and REFOUT output clock edge of Slave mode.

Table 10 RF Function

Setting RF	Description	
	REFIN sampling edge	REFOUT output edge
0	Fall edge	Fall edge
1	Rise edge	Rise edge

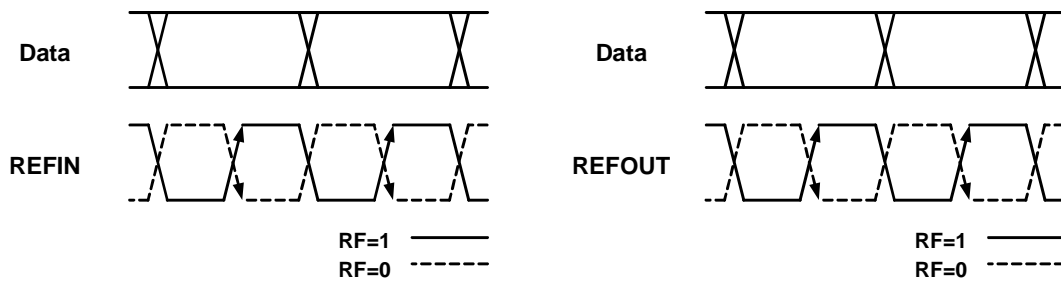

Figure 14 Input / Output clock edge

7.7. Spread Spectrum Clock Generator (SSCG) and REFIN frequency

THCS252 CML serial data output, GPIO data output and clock output are modulated by integrated SSCG. Only Master mode operates SSCG function. The SSCG is enabled by setting SSEN. When SSCG is enabled and operated with an external REF clock, RESET should be released after the input clock has stabilized.

Table 11 SSCG setting registers

Setting	Description
SSEN	
0	SSCG is off.
1	SSCG is on and fixed setting. Modulation rate is ±0.5%. Modulation frequency is 12kHz when f _{CLKSSCG} = FREF = 20MHz. (20MHz / 1664) = 12kHz)

Table 12 f_{CLKSSCG}

Setting			Sampling clock	Sampling clock frequency	f _{CLKSSCG}
REFEN	OSCSEL1	OSCSEL0			
0	0	0	Internal oscillator clock	Low	FREF ^[*1]
	0	1		-	-
	1	0		Low	FREF ^[*1]
	1	1		High	FREF ^[*1] /2
1	-		External reference clock input REFIN	15 – 57MHz	

*1 FREF : Sampling clock frequency

Table 13 External reference clock input frequency range and SSCG setting

Setting	External reference clock input frequency range [MHz]	CML Line multiply ratio	CML Line data rate [Gbps]	SSCG
SSEN				
0	15 - 100	x30	0.45- 3.0	Disable
1	15 - 57	x30	0.45 - 1.71	Enable

7.8. Error detection and indication

THCS252 has READY and INT for indicating Link status of CML Line communication.

READY indicates establishment of communication for GPIOs. INT indicates CML Link communication error.

Table 14 READY and INT

Status		Description
READY	INT [*1]	
0	1 (pull-up)	CML Link communication unlock state GPIO cannot transmit
1	0	CML Link communication lock state Bit level error occurred
	1 (pull-up)	CML Link communication lock state No error

*1 INT buffer type is open-drain. "1" output means pull-up.

7.9. Standby mode

THCS252 operates in Standby mode by setting STANDBY =1. The Standby mode is low power consumption and low frequency sampling rate transmission mode. In Standby mode, THCS252 can transmit up to 8-bits GPIO through handshake communication between Master mode and Slave mode. Polling period is 100ms. READY is also enabled in Standby mode. When handshake communication is completed, READY goes from low to high.

GPIO transmitting pins show in Table 15 are configured to Downstream, Upstream or Static state. On the other hand D4/D15 – D15/D4 are fixed to Static state.

Table 15 Standby mode direction setting

Data Pin for Master mode	D0/D19	=>	D19/D0	Data Pin for Slave mode
	D1/D18	=>	D18/D1	
	D2/D17	=>	D17/D2	
	D3/D16	=>	D16/D3	
	D4/D15	Static	D15/D4	
	D15/D4	Static	D4/D15	
	D16/D3	<=	D3/D16	
	D17/D2	<=	D2/D17	
	D18/D1	<=	D1/D18	
	D19/D0	<=	D0/D19	

“=>” means Downstream (GPIO input in Master mode and GPIO output in Slave mode).
 “<=” means Upstream (GPIO input in Slave mode and GPIO output in Master mode).
 “Static” means GPIO pins are Static state.

8. Package

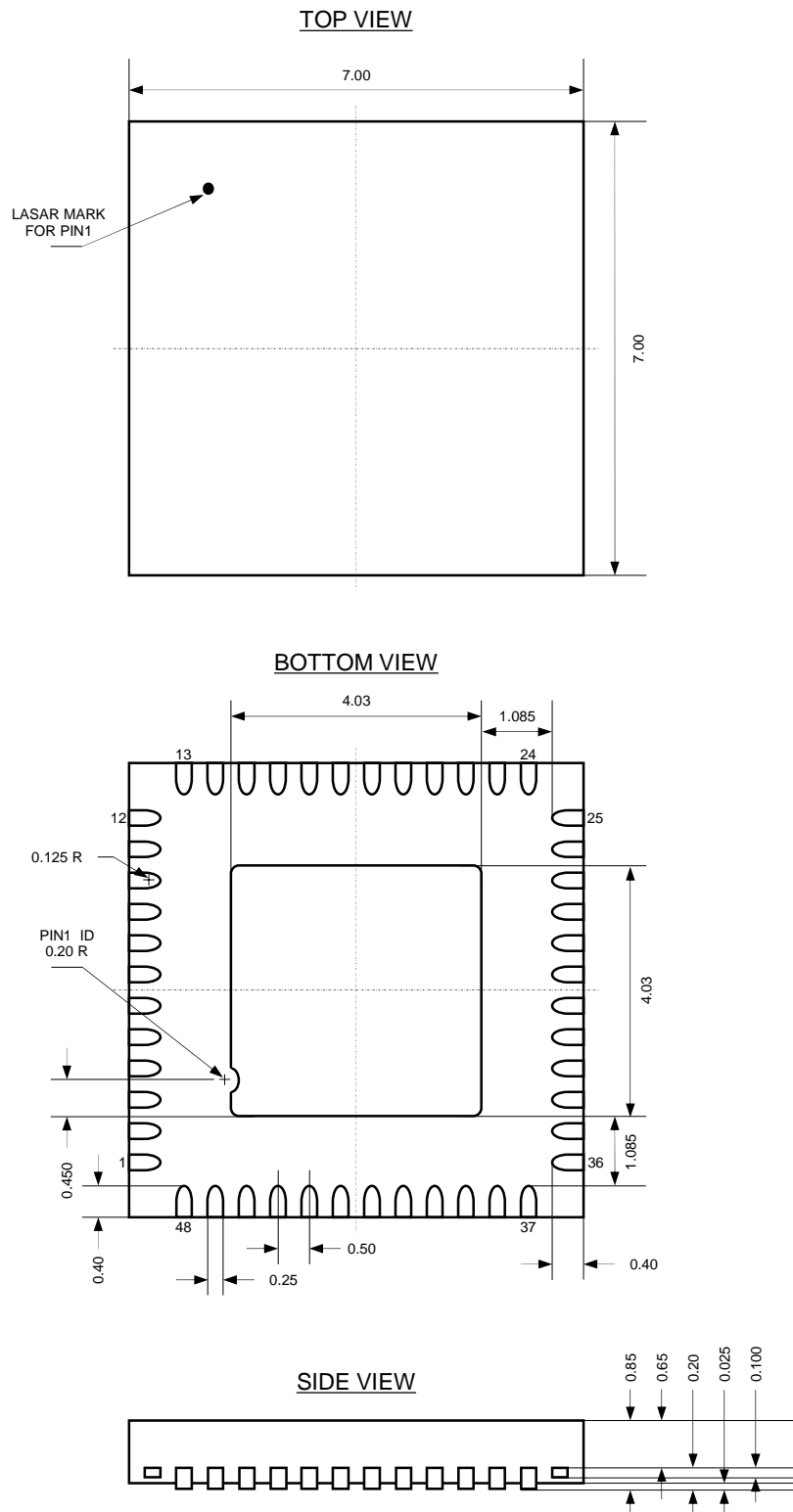

Figure 15 48-pin QFN package physical dimension

9. Unit : mm

Notices and Requests

1. The product specifications described in this material are subject to change without prior notice.
2. The circuit diagrams described in this material are examples of the application which may not always apply to the customer's design. THine Electronics, Inc. ("THine") is not responsible for possible errors and omissions in this material. Please note even if errors or omissions should be found in this material, THine may not be able to correct them immediately.
3. This material contains THine's copyright, know-how or other intellectual property rights. Copying, reverse-engineering or disclosing to third parties the contents of this material without THine's prior written permission is prohibited.
4. Note that even if infringement of any third party's intellectual property rights should occur by using this product, THine will be exempted from the responsibility unless it directly relates to the production process or functions of the product.
5. This product is not designed for applications that require extremely high-reliability/safety such as aerospace device, nuclear power control device, or medical device related to critical care, excluding when this product is specified for automotive use by THine and used it for that purpose. THine accepts no liability whatsoever for any damages, claims or losses arising out of the uses set forth above.
6. Despite our utmost efforts to improve the quality and reliability of the product, faults will occur with a certain small probability, which is inevitable to a semi-conductor product. Therefore, you are encouraged to have sufficiently fail-safe design principles such as redundant or error preventive design applied to the use of the product so as not to have our product cause any social or public damage.
7. This product may be permanently damaged and suffer from performance degradation or loss of mechanical functionality if subjected to electrostatic charge exceeding capacity of the ESD (Electrostatic Discharge) protection circuitry. Safety earth ground must be provided to anything in contact with the product, including any operator, floor, tester and soldering iron.
8. Please note that this product is not designed to be radiation-proof.
9. Testing and other quality control techniques are used to this product to the extent THine deems necessary to support warranty for performance of this product. Except where mandated by applicable law or deemed necessary by THine based on the user's request, testing of all functions and performance of the product is not necessarily performed.
10. Customers are asked, if required, to judge by themselves if this product falls under the category of strategic goods under the Foreign Exchange and Foreign Trade Act in Japan and the Export Administration Regulations in the United States of America on export or transit of this product. This product is prohibited for the purpose of developing military modernization, including the development of weapons of mass destruction (WMD), and the purpose of violating human rights.
11. The product or peripheral parts may be damaged by a surge in voltage over the absolute maximum ratings or malfunction, if pins of the product are shorted by such as foreign substance. The damages may cause a smoking and ignition. Therefore, you are encouraged to implement safety measures by adding protection devices, such as fuses. THine accepts no liability whatsoever for any damage or loss caused to the user due to use under a condition exceeding the limiting values.

12. All patents or pending patent applications, trademarks, copyrights, layout-design exploitation rights or other intellectual property rights concerned with this product belong to THine or licensor(s) of THine. No license or right is granted to the user for any intellectual property right or other proprietary right now or in the future owned by THine or THine's licensor. The user must enter into a license agreement with THine or THine's licensor to be granted of such license or right.

THine Electronics, Inc.

<https://www.thine.co.jp>