



THCV242-Q

SerDes receiver with bi-directional transceiver

1. General Description

THCV242-Q is designed to support 1080p60 2Mpixel uncompressed video data over 15m 100ohm differential STP or single-end 50ohm Coaxial cable with 4 in-line connectors between camera and processor by V-by-One® HS.

THCV242-Q supports a MIPI CSI-2. Each CSI-2 data lane can transmit up to 1.2Gbps/lane. Virtual channel is supported. MIPI 2nd port output supports data copy and distribution.

One high-speed V-by-One® HS lane can transmit up to 1080p60fps. The maximum serial data rate is 4Gbps/lane. 2nd input lane supports HDR large amount of data or camera switch experience.

THCV242-Q is capable to control and monitor remote camera module from MPU via GPIO or 1Mbps 2-wire serial interface.

Several fault and error detection function including CRC provides hardware functional safety design.

2. Features

- MIPI CSI-2 with 1,2 or 4-lane output
- MIPI D-PHY supports 80Mbps~1.2Gbps
- Video formats: RAW8/10/12/14/16/20, YUV422/420, RGB888/666/565, JPEG, User-defined generic 8-bit
- V-by-One® HS 400Mbps~4Gbps x2lane
- V-by-One® HS standard version1.5
- Video stream switch and copy/distribution
- Frame sync remote supply scheme for multiple camera stream synchronization
- Wide range IO voltage from 1.7V to 3.6V
- 2-wire serial interface 1Mbps bridge function
- Remote GPIO/UART control and monitoring
- Error detection including CRC and notification
- QFN64 9x9mm 0.5mm pitch Exp-pad package
- AEC-Q100 Support

3. Block Diagram

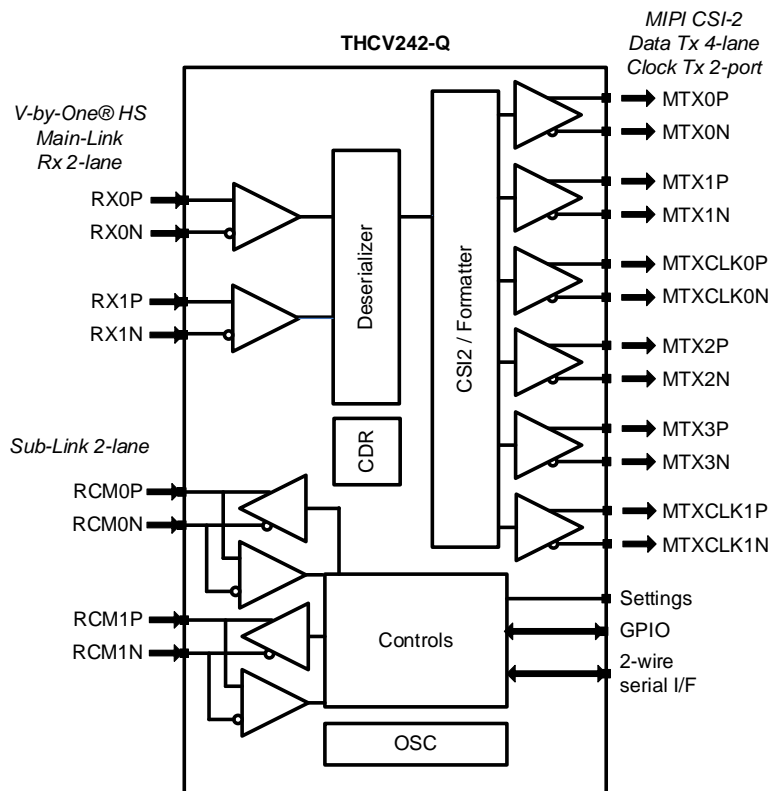

4. Package

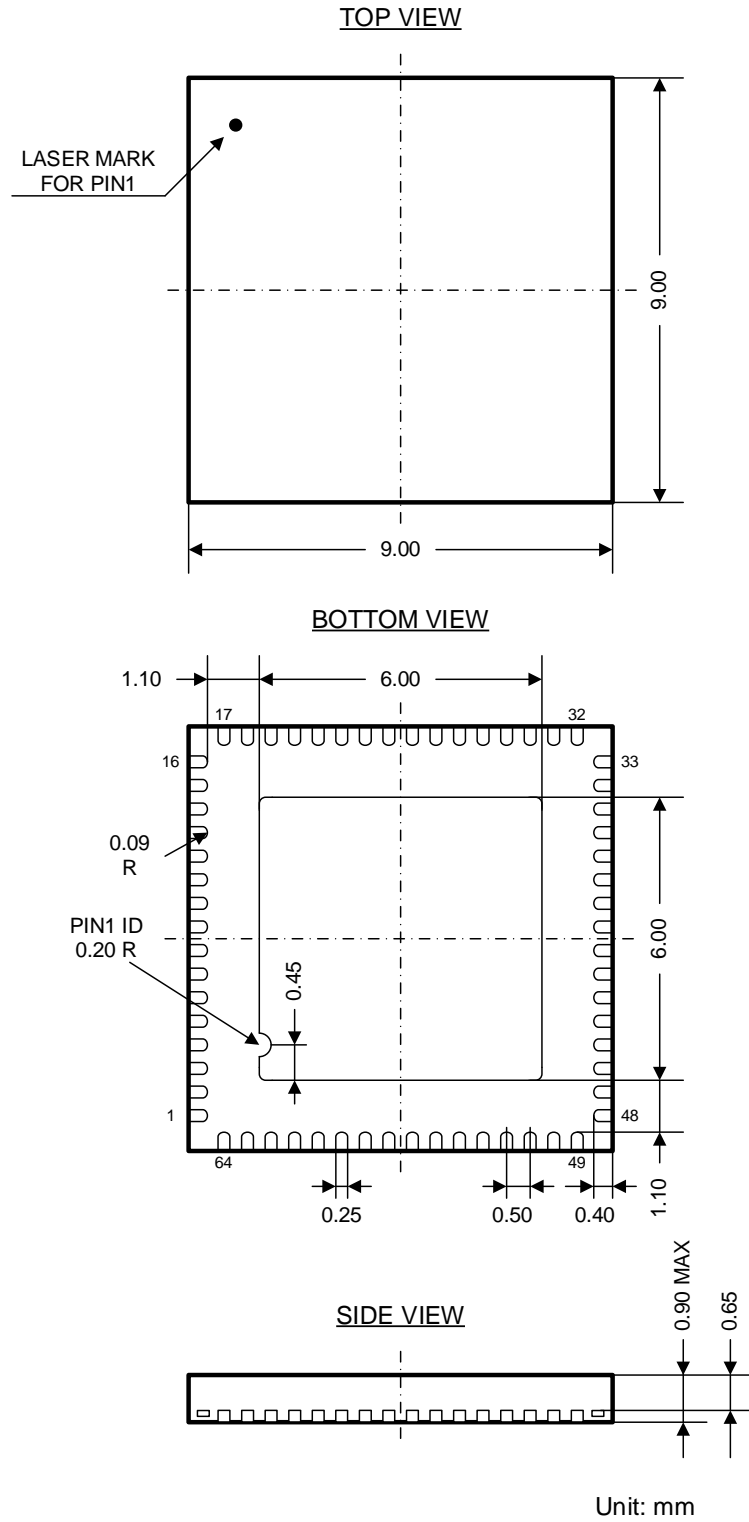

5. Notices and Requests

1. The product specifications described in this material are subject to change without prior notice.
 2. The circuit diagrams described in this material are examples of the application which may not always apply to the customer's design. THine Electronics, Inc. ("THine") is not responsible for possible errors and omissions in this material. Please note even if errors or omissions should be found in this material, THine may not be able to correct them immediately.
 3. This material contains THine's copyright, know-how or other proprietary. Copying or disclosing to third parties the contents of this material without THine's prior permission is prohibited.
 4. Note that even if infringement of any third party's industrial ownership should occur by using this product, THine will be exempted from the responsibility unless it directly relates to the production process or functions of the product.
- ### 5. Product Application
- 5.1 Application of this product is intended for and limited to the following applications: audio-video device, office automation device, communication device, consumer electronics, smartphone, feature phone, and amusement machine device. This product must not be used for applications that require extremely high-reliability/safety such as aerospace device, traffic device, transportation device, nuclear power control device, combustion chamber device, medical device related to critical care, or any kind of safety device.
 - 5.2 This product is not intended to be used as an automotive part, unless the product is specified as a product conforming to the demands and specifications of IATF16949 ("the Specified Product") in this data sheet. THine accepts no liability whatsoever for any product other than the Specified Product for it not conforming to the aforementioned demands and specifications.
 - 5.3 THine accepts liability for demands and specifications of the Specified Product only to the extent that the user and THine have been previously and explicitly agreed to each other.
6. Despite our utmost efforts to improve the quality and reliability of the product, faults will occur with a certain small probability, which is inevitable to a semi-conductor product. Therefore, you are encouraged to have sufficiently redundant or error preventive design applied to the use of the product so as not to have our product cause any social or public damage.
 7. Please note that this product is not designed to be radiation-proof.
 8. Testing and other quality control techniques are used to this product to the extent THine deems necessary to support warranty for performance of this product. Except where mandated by applicable law or deemed necessary by THine based on the user's request, testing of all functions and performance of the product is not necessarily performed.
 9. Customers are asked, if required, to judge by themselves if this product falls under the category of strategic goods under the Foreign Exchange and Foreign Trade Act.
 10. The product or peripheral parts may be damaged by a surge in voltage over the absolute maximum ratings or malfunction, if pins of the product are shorted by such as foreign substance. The damages may cause a smoking and ignition. Therefore, you are encouraged to implement safety measures by adding protection devices, such as fuses.

THine Electronics, Inc.

<https://www.thine.co.jp>