

THPM4601A

4-16V Input 12A Output POL Power Module

Features

- Integrated Point of Load power module
- Small Footprint, low-profile, 15.2mm x 15.2mm x 3.2mm, with LGA Package (0.63mm pads)
- Up to 12A maximum output current
- Efficiency up to 93.5% at 12A and 95% at 6A
- Single resistor output voltage programming for voltages from 0.6V to 5.5V
- Output voltage differential remote sensing
- Input voltage range 4V to 16V
- 1 MHz switching frequency
- Enable signal input and Power Good signal output
- Output voltage sequencing
- Pre-bias startup
- Programmable Under Voltage Lock Out (UVLO)
- Output Over-Current Protection (OCP)
- Over-temperature Protection (OTP)
- Operating temperature range -40°C to 85°C

Applications

- Broadband and communications equipment
- DSP and FPGA Point of Load applications
- High density distributed power systems
- PCI / PCI express / PXI express
- Automated test and medical equipment

Description

THPM4601A is an easy-to-use 12A output integrated Point of Load (POL) power supply module. It contains power MOSFETs, driver, PWM controller, a high-performance inductor, input and output capacitors and other passive components in one low profile LGA package.

There is no need for loop compensation, inductor selection, or in-circuit production testing.

The THPM4601A can be programmed for any output voltage between 0.6V and 5.0V using a single external resistor. For an output voltage of 0.6V no resistor is required.

Small size (15.2mm x 15.2mm) and low profile (3.2mm) allows the THPM4601A to be placed very close to its load, or on the back side of the PCB board for high density applications.

Constant on-time (COT) control achieves excellent transient response to line and load changes without sacrificing stability and high efficiency at light load.

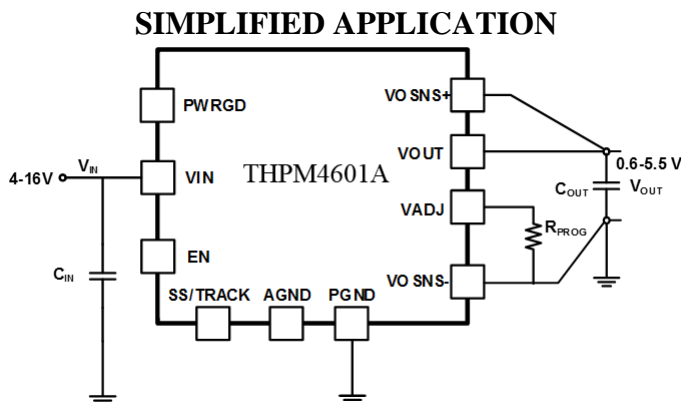

EFFICIENCY VS LOAD CURRENT

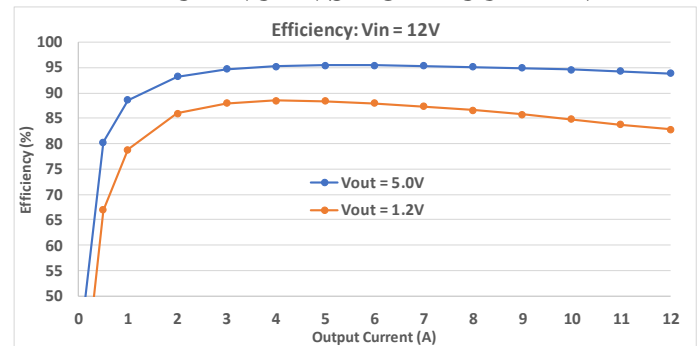

ABSOLUTE MAXIMUM⁽¹⁾ RATINGS over operating temperature range (unless otherwise noted)

		VALUE		Unit
		MIN	MAX	
Inputs	VIN	-0.3	18	V
	EN	-0.3	4.3	V
	VOSNS+	VOUT-0.3V	VOUT+0.3V	V
	VADJ	-0.3	4.3	V
Outputs	VOUT	-0.6	9.7	V
	PWRGD	-0.3	4.3	V
Temperature	Operating Junction Temperature	-	150	°C
	Storage Temperature	-55	150	°C
	Peak solder reflow body temperature	-	245	°C

(1) Stresses beyond these absolute maximum ratings may cause permanent damage to the device. These are stress ratings only, and functional operation of the device at these or any other conditions beyond those indicated under recommended operating conditions is not implied. Exposure to absolute-maximum-rated conditions for extended periods may affect device reliability.

Ordering Information

Output Voltage	Module Part Number	Pad Finish	Package Type	Temperature Range
Adjustable	THPM4601A	Au (RoHS)	LGA	-40°C to 85°C

ELECTRICAL CHARACTERISTICS

The electrical performance is based on the following conditions unless otherwise stated: 25°C ambient temperature, no air flow; $V_{IN} = 12V$, $V_{OUT} = 1.8V$, $I_{OUT} = 12A$, $C_{IN} = 3 \times 22\mu F$ ceramic plus 150 μF electrolytic, $C_{OUT} = 4 \times 22\mu F$ plus 2x47 μF ceramic.

PARAMETERS		TEST CONDITIONS	MIN	TYP	MAX	UNIT	
Input Specifications							
V_{IN}	Input voltage	Over I_{OUT} range	4	12	16	V	
V_{START}	Start up voltage [Note 1]	Over I_{OUT} range	-	3.1	-	V	
V_{EN_ON}	Enable input voltage	Enable high voltage (module turned on)	1.17	-	-	V	
		Enable low voltage (module turned off)	-	-	0.97	V	
UVLO Under Voltage Lock Out [Note 1]			-	3.0	-	V	
UVLO Hysteresis			-	0.1	-	V	
Output Specifications							
I_{OUT} :	Output continuous current	$T_A = -40^\circ C$ to $85^\circ C$, natural convection (derated above $50^\circ C$, refer to 0)	0	-	12	A	
V_{OUT}	Set point accuracy [Note 2]	$T_A = 25^\circ C$, $V_{IN} = 12V$, $I_{OUT} = 6A$	-	$\pm 0.8\%$	-	-	
	Temperature variation	$-40^\circ C < T_A < +85^\circ C$, $I_{OUT} = 6A$	-	$\pm 0.5\%$	-	-	
	Line regulation	Over V_{IN} range, $T_A = 25^\circ C$, $I_{OUT} = 6A$	-	$\pm 0.5\%$	-	-	
	Load regulation	Over I_{OUT} range, $T_A = 25^\circ C$, $V_{IN} = 12V$	-	$\pm 1\%$	-	-	
$V_{OUT(adi)}$:	Output voltage adjust range	Over I_{OUT} range [Note 3]	0.6	-	5.5	V	
V_{o_rip} ,	Output voltage ripple	20MHz bandwidth, $V_{IN} = 12V$, $I_{OUT} = 12A$	-	20	-	mVpp	
OVP	Over-voltage Protection	OVP threshold (percentage of nominal)	113%	116%	119%	-	
UVP	Under-voltage Protection	UVP threshold (percentage of nominal)	77%	80%	83%	-	
PWRGD	Power Good Signal	V_{OUT} rising (% of V_{OUT})	PWRGD high	89.5%	92.5%	95.5%	-
			PWRGD delay	-	0.8	-	ms
		V_{OUT} falling (% V_{OUT})	PWRGD low	77%	80%	83%	-
			PWRGD high	113%	116%	119%	-
	Sink current	I_{PG}	-	-	10	mA	
F_S	Switching frequency	$V_{IN} = 12V$, $I_{OUT} = 12A$	-	1	-	MHz	
Performance Specifications							
η	Efficiency ($V_{OUT} = 5V$)	$V_{IN} = 12V$, $T_A = 25^\circ C$	$I_{OUT} = 6A$	-	95%	-	-
			$I_{OUT} = 12A$	-	93.8%	-	-
Soft-Start Time [Note 4]		$V_{IN} = 12V$, $T_A = 25^\circ C$, Over I_{OUT} range	-	1.7	-	ms	
Current Limit and Thermal Specifications							
I_{LIM}	Current Limit Point	$V_{IN} = 12V$, $T_A = 25^\circ C$	-	14	-	A	
Thermal shutdown (die temperature)	Thermal shutdown		-	160	-	$^\circ C$	
	Thermal shutdown recovery hysteresis		-	30	-	$^\circ C$	

Note 1: Startup voltage and UVLO are with no external resistor; startup and UVLO can be increased using an external programming resistor divider – refer to Startup Voltage section of datasheet.

Note 2: With 0.1% tolerance external voltage set resistor. Use 200ppm/ $^\circ C$ programming resistor for best thermal stability.

Note 3: Required minimum V_{IN} voltage is typically 50% higher than V_{OUT} to keep good regulation on output over full load range.

Note 4: Soft-start time can be increased by adding external C_{SS} capacitance at the SS pin.

POWER MODULE INFORMATION

FUNCTIONAL BLOCK DIAGRAM for THPM4601A

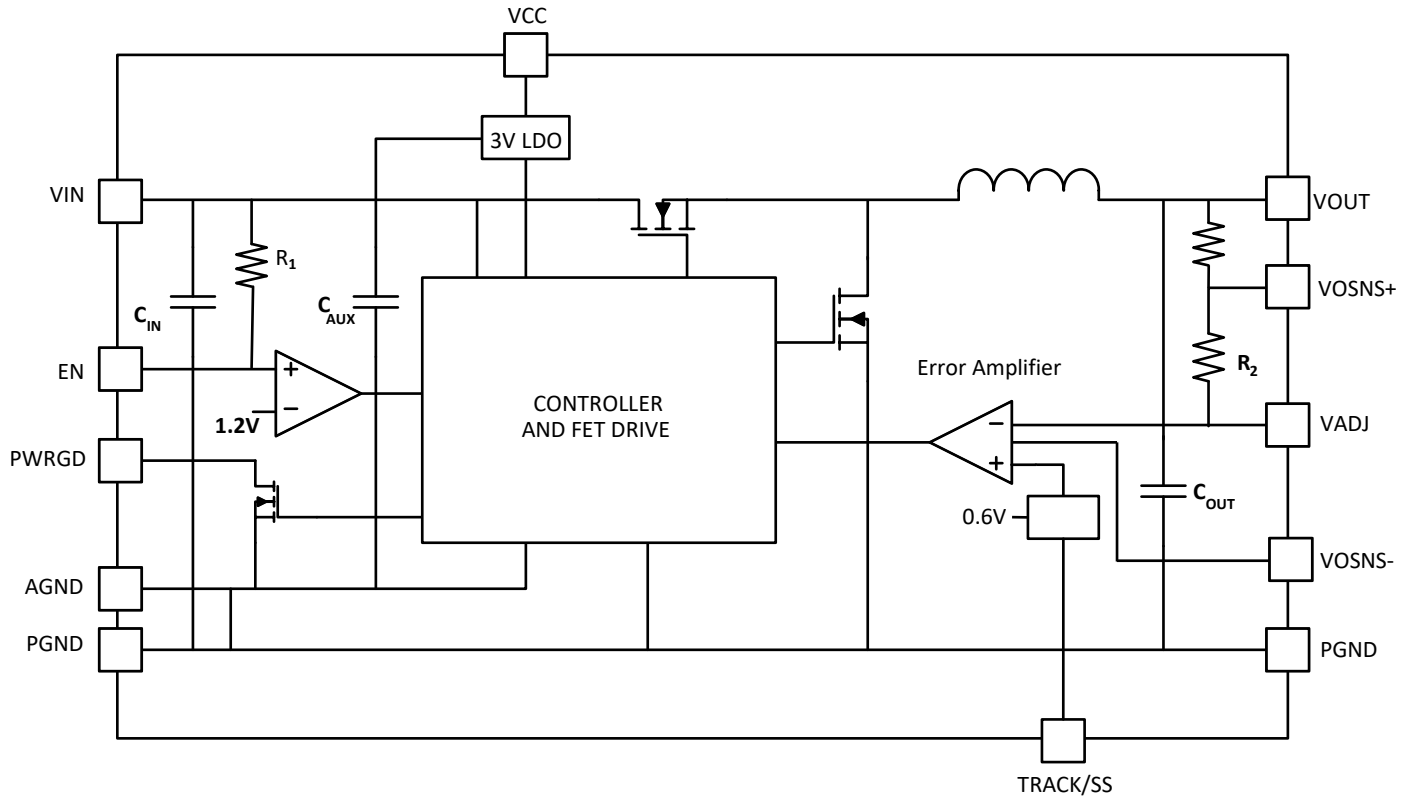

PIN DESCRIPTIONS

PIN Name	Description
VIN (A1-A6, B1-B6, C1-C6)	Input voltage pins, referenced to PGND. Connect input ceramic capacitors between these pins and PGND plane, close to the power module.
VCC (A7, D9)	Internal supply voltage from a 3V LDO in the module, which is referenced to AGND. An external capacitor is not normally necessary.
VOUT (J1-J10, K1-K11, L1-L11, M1-M11)	Output voltage pins. Connect these pins together onto a copper plane. Connect external output filter capacitors between these pins and PGND plane, close to the device.
PGND (B7, B9, C7, C9, D1-D6, D8, E1-E7, E9, F1-F9, G1-G9, H1-H9)	Zero DC voltage output for power circuitry. These pins should be connected directly to the PCB ground plane. All pins must be connected together externally with a copper plane directly under the module. Connect to large PGND planes for better heat dissipation.
AGND (G11, H11, H12)	Zero DC voltage reference for the analog control circuitry. A small analog ground plane is recommended that does not carry load or any other high current. VCC should be referenced to analog ground.
EN (A10)	Enable. When the voltage on this pin is above Enable ON Voltage (V_{EN_ON}), the power module will be turned on when the power input voltage (VIN) is above start up voltage (V_{START}). When EN pin is below Enable Off Voltage (V_{EN_OFF}), the power module will be off.
VADJ (F12)	Output voltage programming. Connect a resistor between this pin and VOSNS- to set the output voltage.
TRACK/SS (A9)	Tracking/soft start. An external capacitor connected between this pin and VOSNS- can be used to increase the soft start time.
VOSNS+ (J12, L12)	Remote sensing (positive). Connect this pin to VOUT close to the load for improved voltage regulation. Note: this pin is internally connected to VOUT inside the module, with a 49.9 ohms resistor to prevent high output voltage in case of feedback loop disconnection outside the module.
VOSNS- (M12)	Remote sensing (negative). Connect this pin the point of regulation on the load return and decoupling capacitors (PGND) for proper voltage sensing and regulation. This pin the reference for voltage setting resistor and soft start capacitor. Note: this pin is not connected to AGND or PGND inside the module and must be connected externally to PGND.
NC (A8, A11, A12, B11, C12, D12, E12, K12)	No connect. There is no connection to these pins. Leave open or connect to PGND
DNC (B12, C11)	Do not connect: Leave these pins open. Can be used for soldering to open pads.
MTP1, MTP2, MTP3 (C10, D10, D11)	Mounting pads. These are extra pads for improved soldering and should be left open circuit.
PWRGD (F11, G12)	Power Good, an open drain output. A resistor (10K typical) is connected between PWRGD and VCC or a 3.3V dc source. PWRGD is high if the output voltage is higher than 92.5% of the nominal value. It will be pulled down if the output voltage is less than 80% or higher than 116% of the nominal value.

**LGA PACKAGE
133 PINS,
(TOP VIEW)**

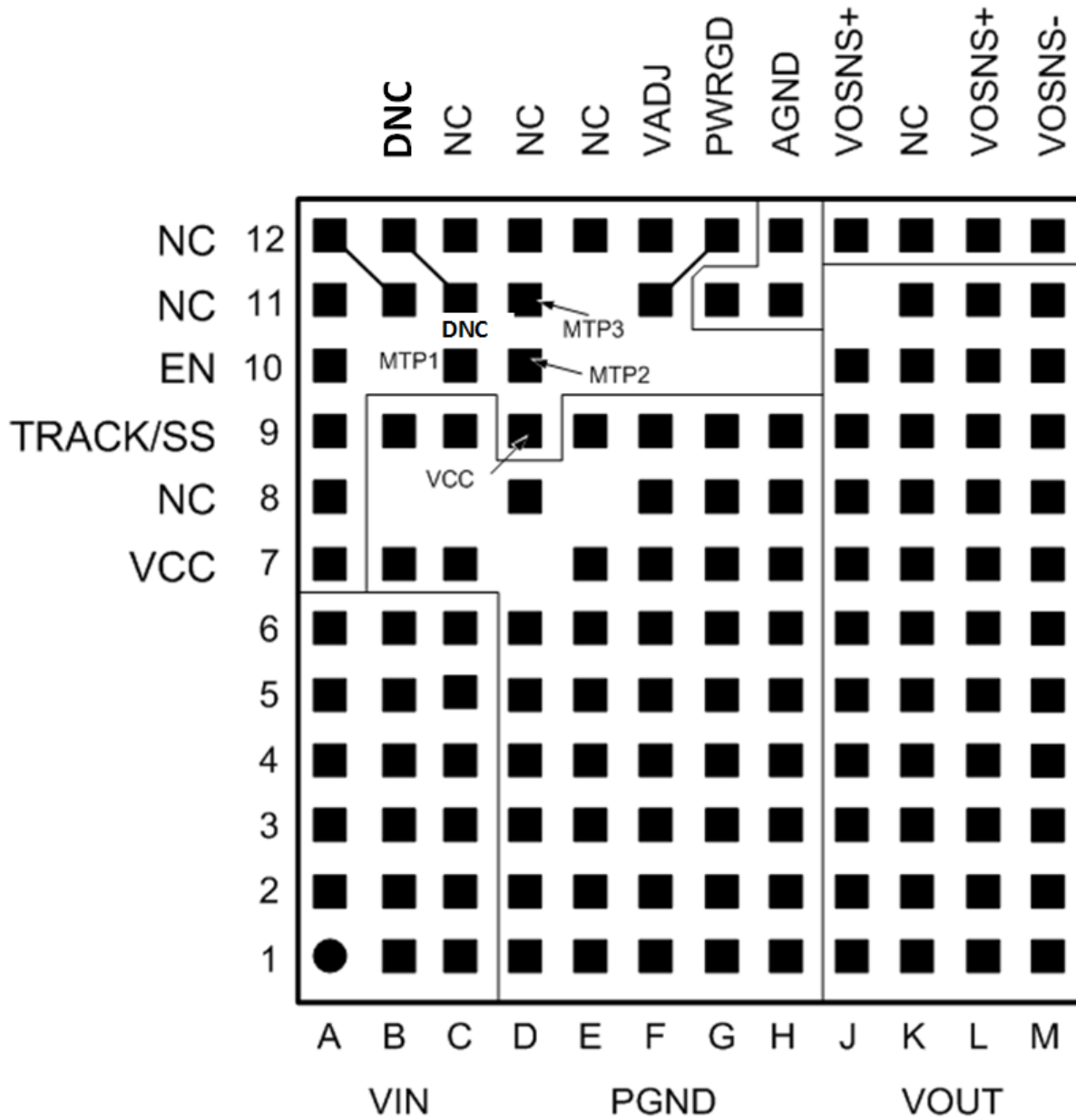

TYPICAL EFFICIENCY, POWER LOSS AND REGULATION

$V_{OUT} = 5V, T_A = 25^{\circ}C$

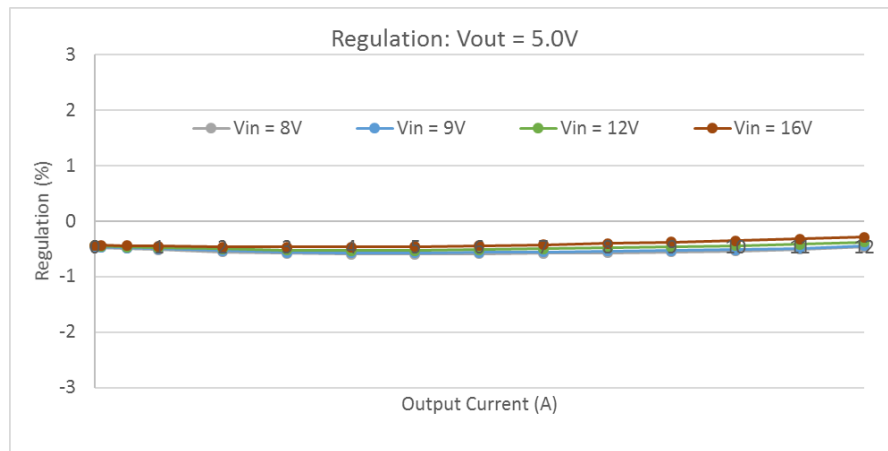
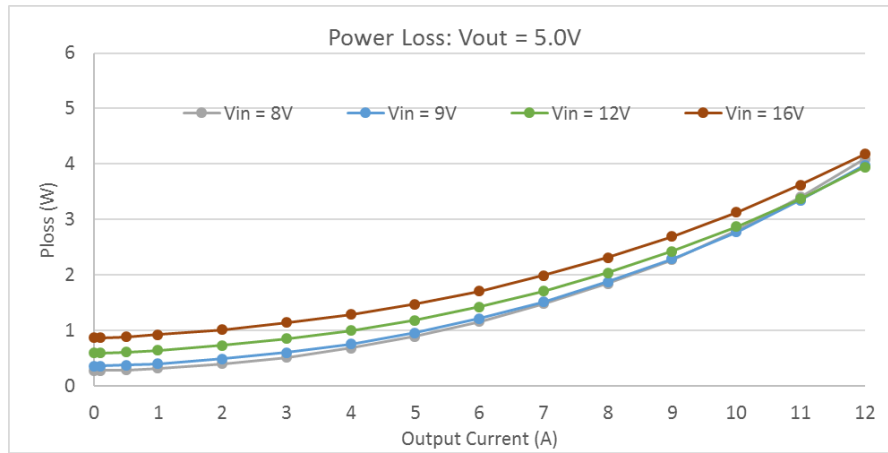
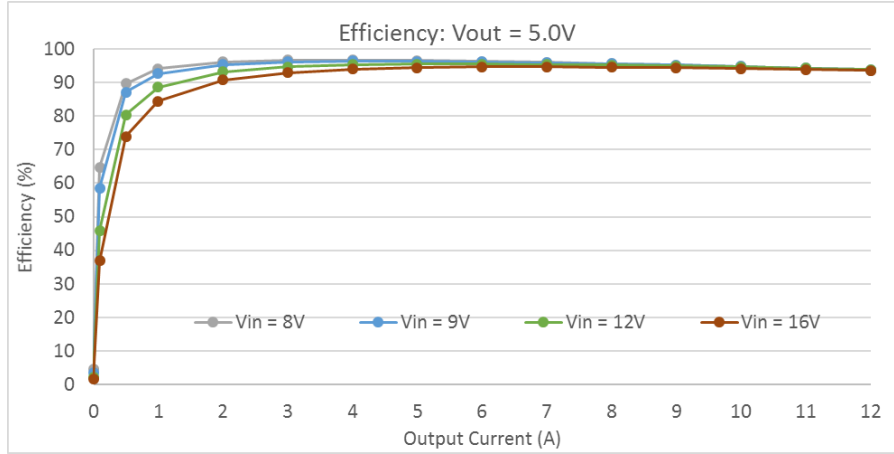

$V_{OUT} = 3.3V, T_A = 25^{\circ}C$

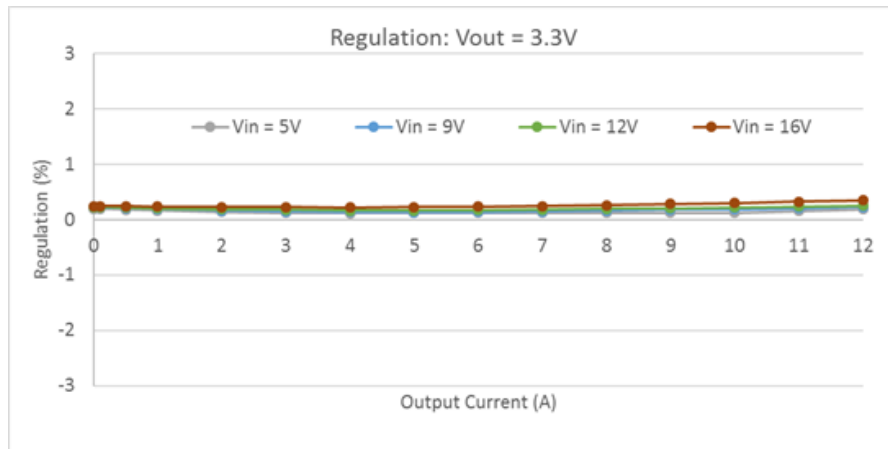
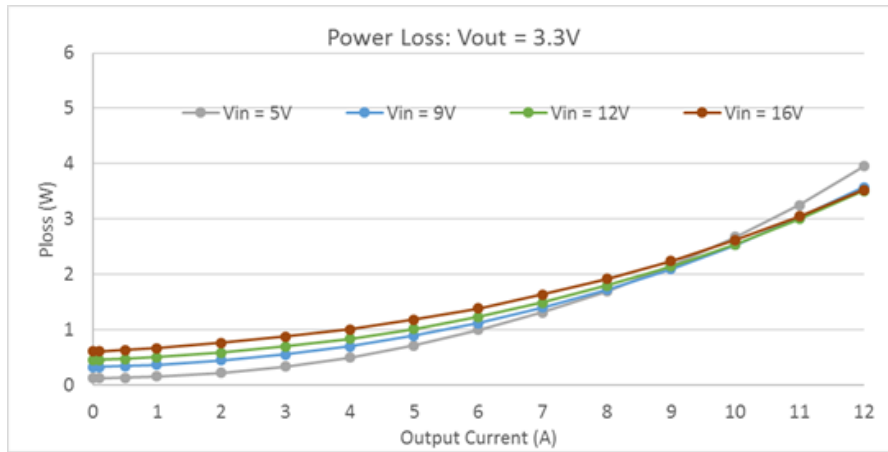
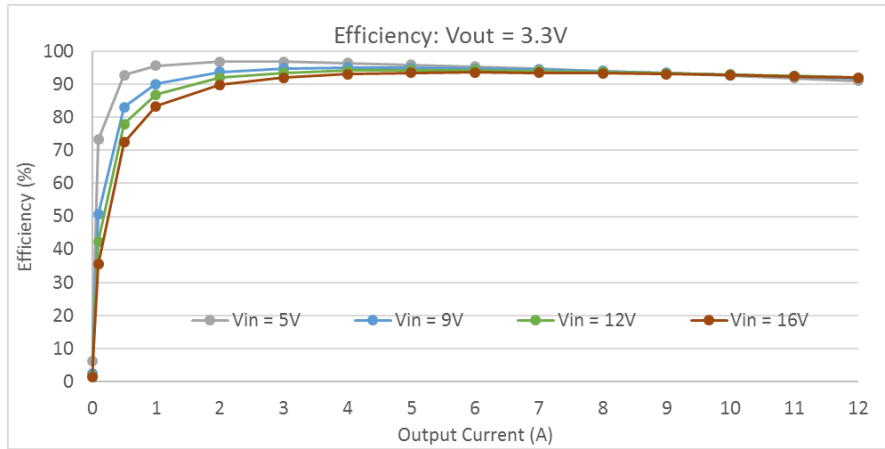

$V_{OUT} = 1.8V, T_A = 25^{\circ}C$

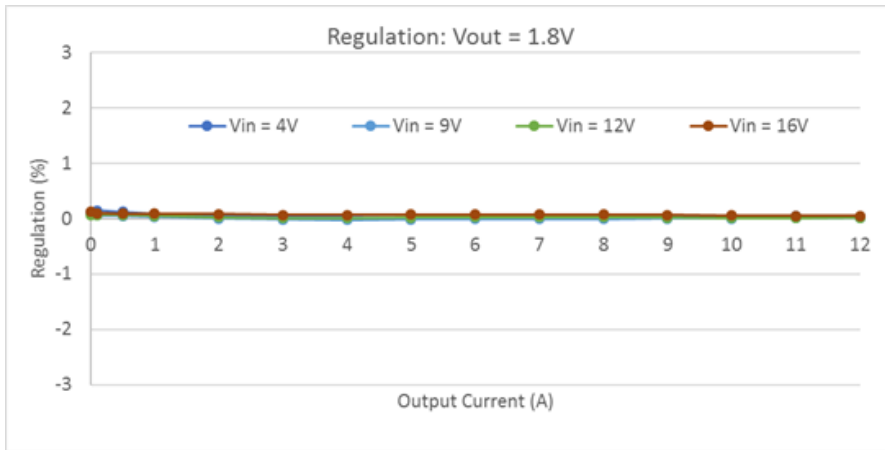
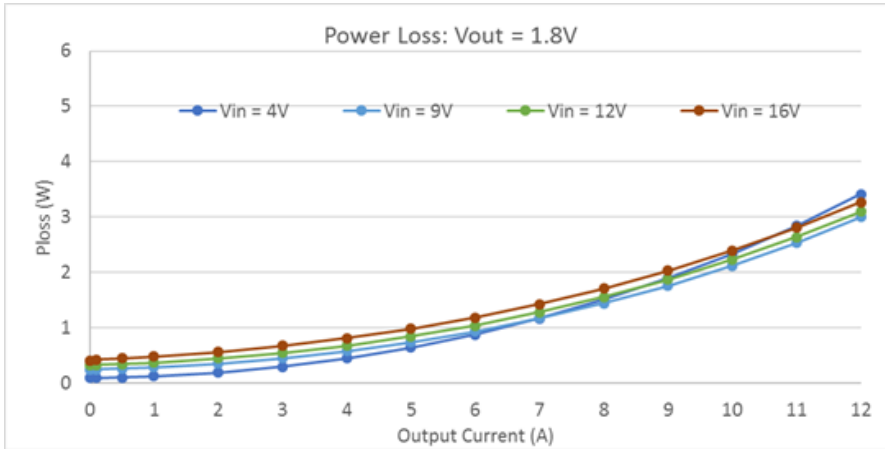
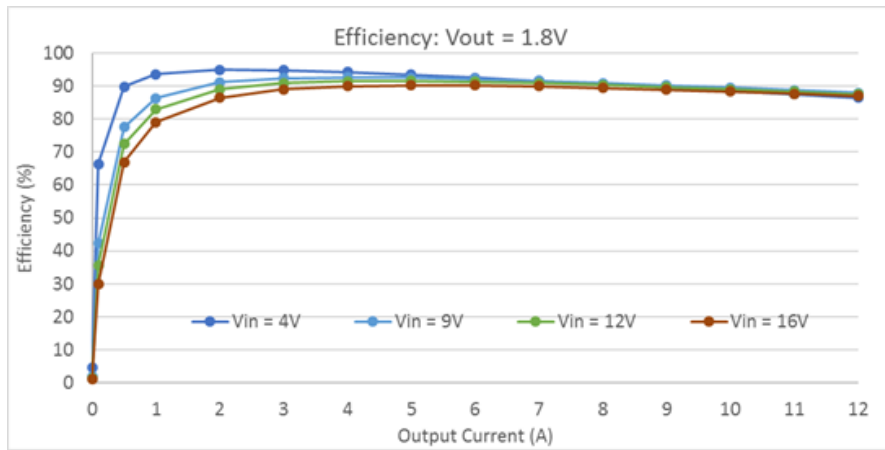

$V_{OUT} = 1.2V, T_A = 25^{\circ}C$

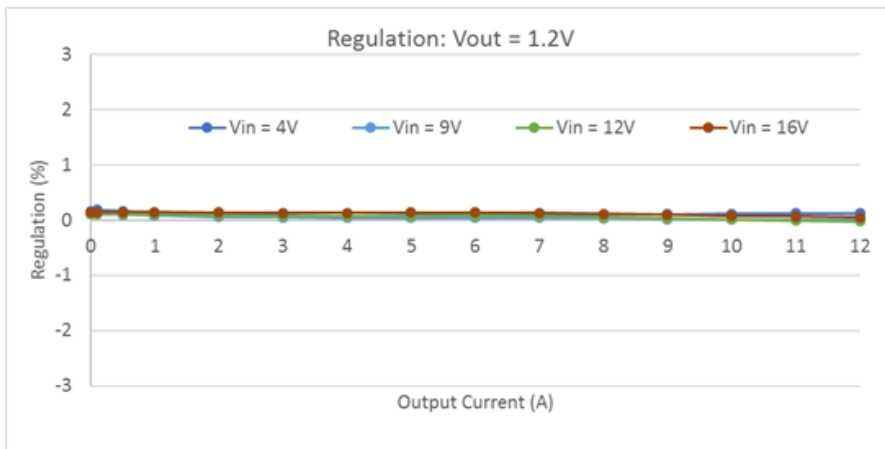
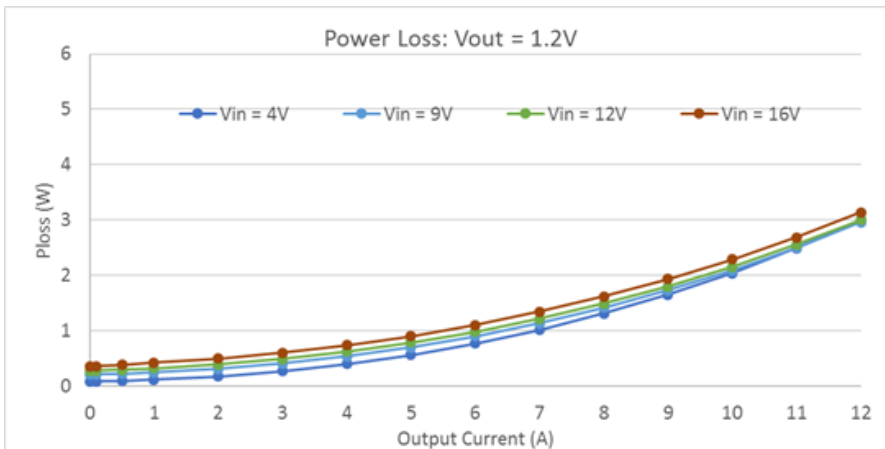
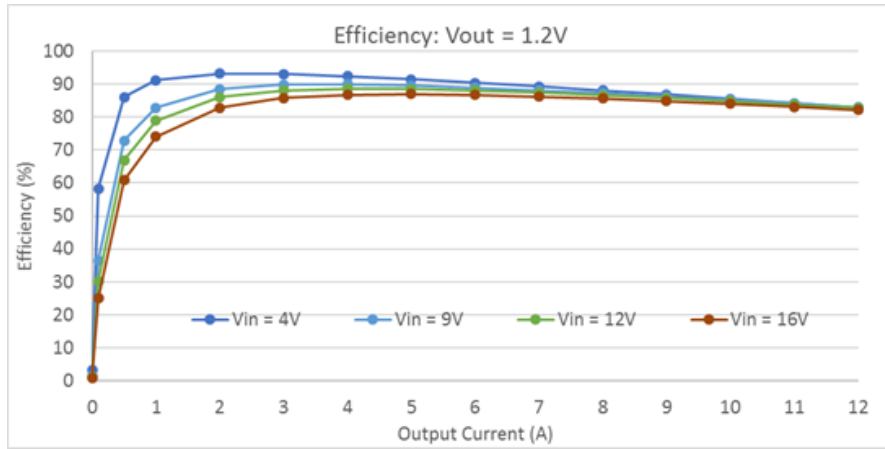

$V_{OUT} = 0.6V, T_A = 25^{\circ}C$

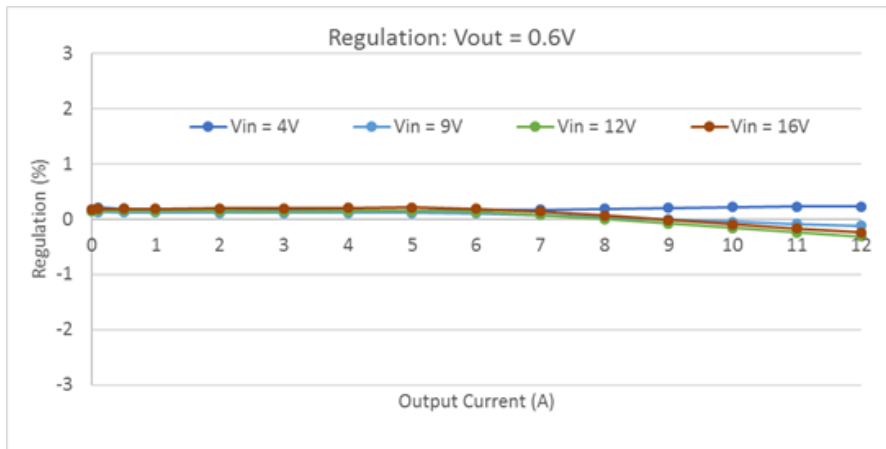
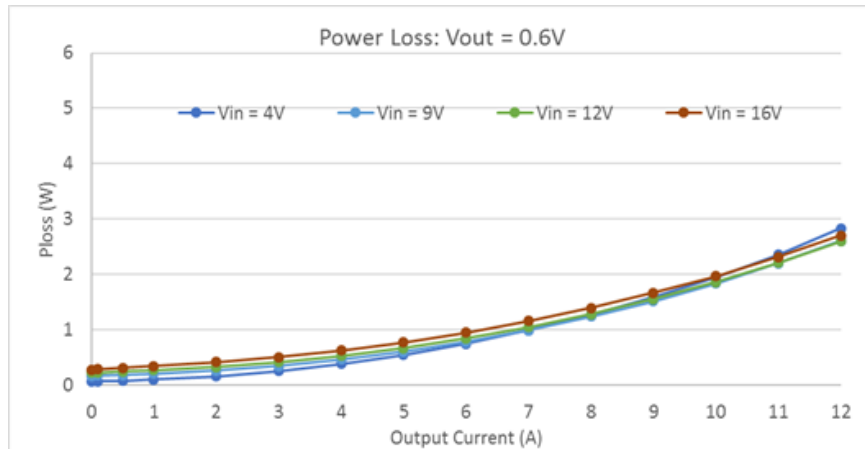
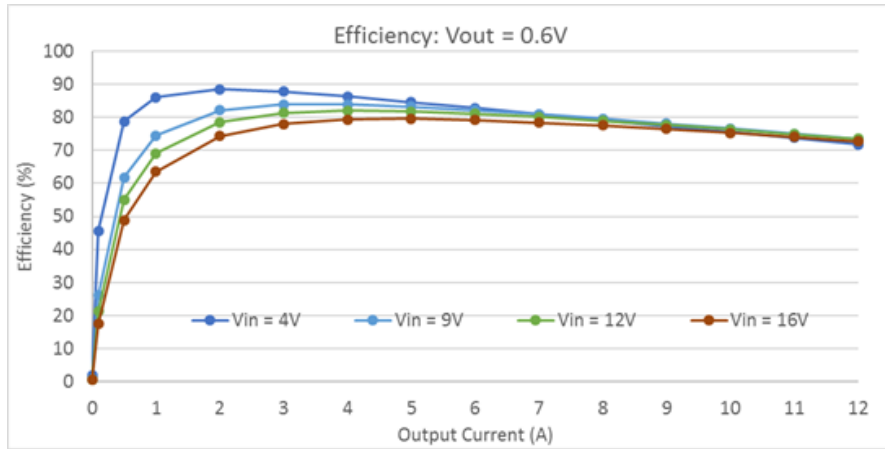

APPLICATION INFORMATION

Output Voltage Programming

The output voltage is programmed using a resistor R_{PROG} from VADJ to VOSNS-, as shown in Fig. 1. By default, the output voltage is 0.6V without a resistor connected. Differential remote sense pins VOSNS+ and VOSNS- should be connected directly to the output remote sense point as indicated.

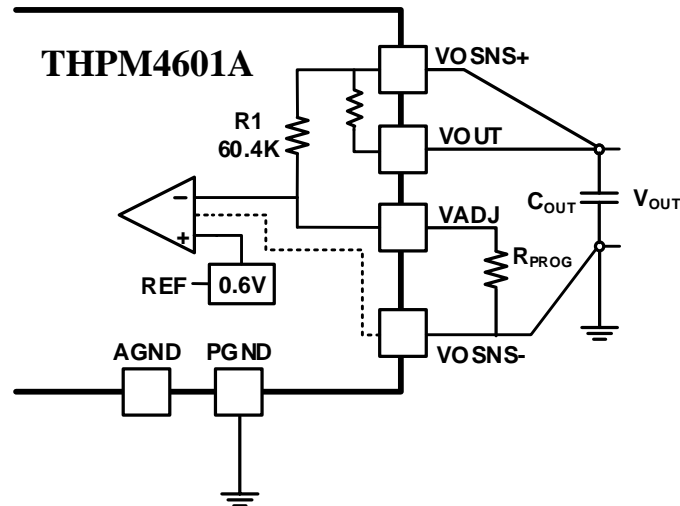

Fig. 1: Output Voltage Programming Circuit

A single standard resistor can be used to program for any of the common voltages shown in Table 1. The V_{PROG} shows the desired set value for V_{OUT} and V_{SET} shows the actual set value using a standard resistor. For applications requiring a more temperature stable voltage set-point, it is recommended to use programming resistors with 200ppm/°C thermal coefficient placed close to the module to get almost the same temperature. The programming resistor can be calculated for any output voltage using equation (1).

$$R_{PROG(k\Omega)} = \frac{36.24}{V_{OUT} - V_{Ref}} ; \quad V_{Ref} = 0.6V \quad (1)$$

Table 1 - Output Voltage Programming Resistor

Output Voltage V_{PROG}	0.6V	0.8V	1.0V	1.2V	1.5V	1.8V	2.5V	3.3V	5V	5.5V
Calculated R_{PROG}	open	181.2k Ω	90.6k Ω	60.4k Ω	40.27k Ω	30.2k Ω	19.07k Ω	13.42k Ω	8.24k Ω	7.396k Ω
Standard 0.1% R_{PROG}	NO	182K Ω	90.9K Ω	60.4K Ω	40.20K Ω	30.10K Ω	19.1K Ω	13.3K Ω	8.25K Ω	7.32K Ω
V_{SET}	0.6V	0.7991V	0.9987V	1.2V	1.5015V	1.8040V	2.4974V	3.325V	5.020V	5.55 V

Note that the VADJ pin is noise sensitive and the connections to this pin should be kept as short as possible.

To further improve the set-point accuracy, two resistors can be used in series or in parallel for R_{PROG} or another R_{TRIM} resistor can be used between VOSNS+ and VADJ pins as shown Fig. 2. The resulting output voltage after using an optional R_{TRIM} resistor is given in equation (2).

$$V_{OUT} = V_{Ref} \left(1 + \frac{R_{TRIM} * 60.4k\Omega}{(R_{TRIM} + 60.4k\Omega) R_{PROG}} \right); \quad V_{Ref} = 0.6V \quad (2)$$

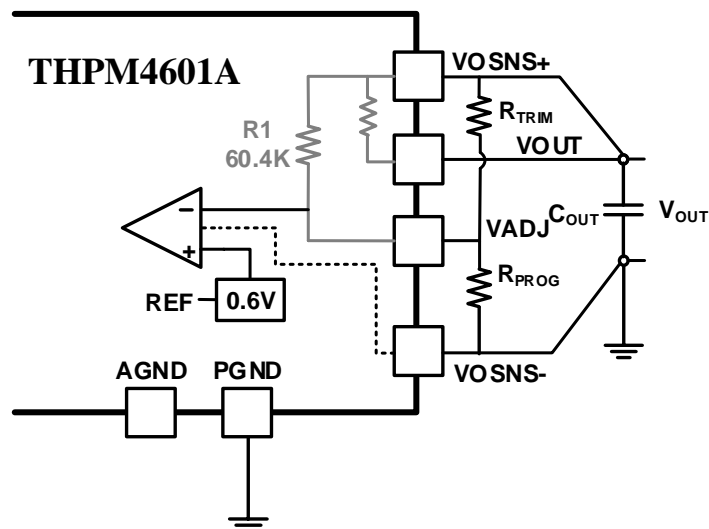

Fig. 2: Output Voltage Trim Circuit

Enable (EN) Control

The EN pin provides an electrical on/off control of the power module. Once the voltage at the EN pin exceeds the threshold voltage (1.2V typical) or is left open, the power module starts operation when the input voltage is higher than the input start-up voltage (V_{START}).

When the voltage at EN pin is pulled below the threshold voltage (1.0V typical), the switching converter stops switching and the power module enters low quiescent current state.

If an application requires controlling the EN pin, an open drain or open collector output logic can be used to interface with the pin, as shown in Fig. 3, where high ON/OFF signal applied to the transistor (low EN) disables the power module. An internal 100K pull up resistor is connected between EN and VIN.

When EN pin is open (or connected to a logic high voltage), THPM4601A produces a regulated output voltage following the application of a valid input voltage. Fig. 4 shows the startup waveform for THPM4601A without EN control. The top trace is input voltage, the middle trace is Power Good signal (PWRGD), and the bottom trace is the output voltage.

Fig. 5 and Fig. 6 show the typical output voltage waveforms when THPM4601A is turned on and turned off by the EN pin. In these figures, the top trace is Enable signal (EN), the middle trace is Power Good signal (PWRGD), and the bottom trace is the output voltage.

The startup and shutdown waveforms are similar for other output voltages.

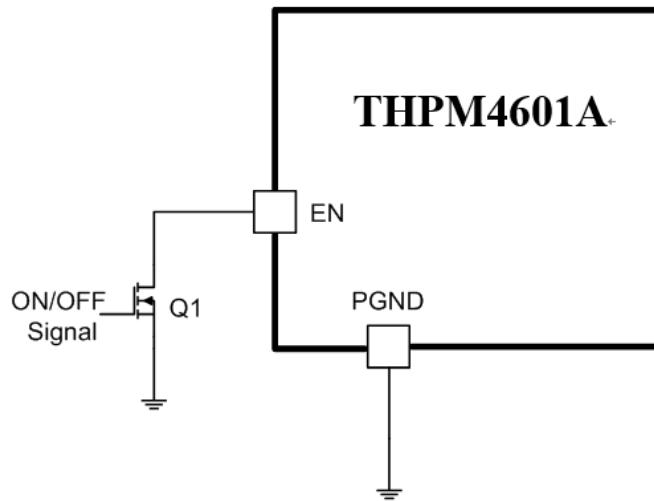

Fig. 3: Typical ON/OFF Control

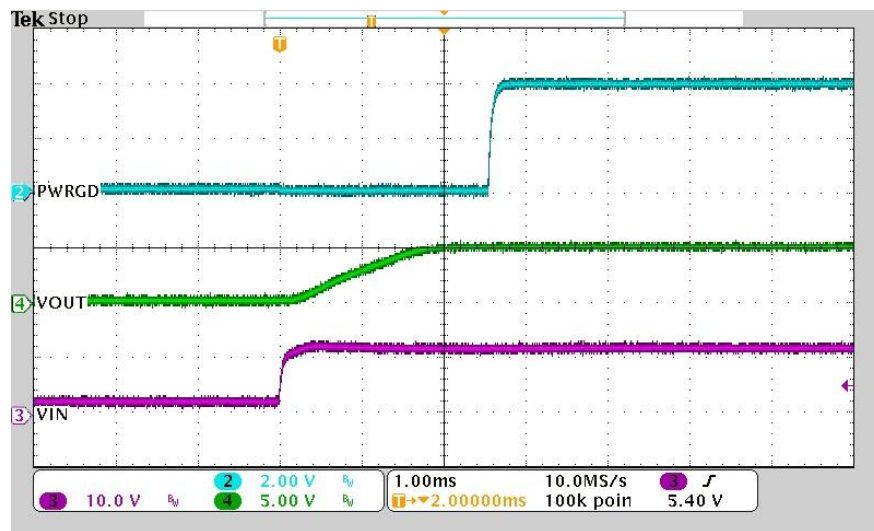

Fig. 4: Typical Power up Start-Up of the THPM4601A without EN control (Vout, set to 5V)

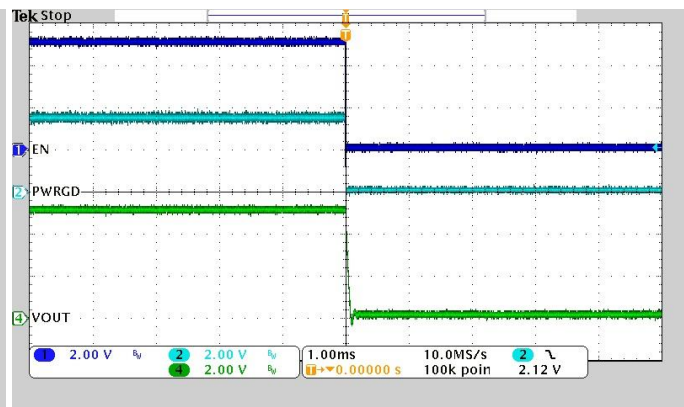
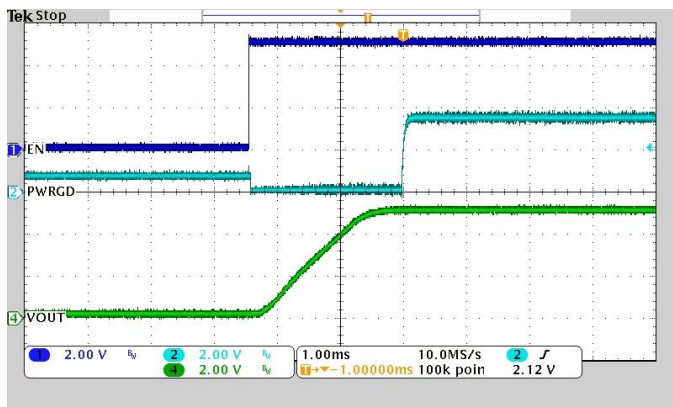

Fig. 5: THPM4601A Enable Turn-On (Vout=5V, Iout=12A) Fig. 6: THPM4601A Enable Turn-Off (Vout=5V, Iout=12A)

Pre-bias Startup

Some applications require startup when there is a residual pre-bias voltage on the output due to previously charged capacitors or another bias sources such as ICs with pins connected to other voltage sources. The THPM4601A can start in this condition and as long as the pre-bias voltage is lower than the final output the start-up waveform will be normal. Fig. 7 illustrates start up with pre-bias of approximately 3.3V when the output voltage is set to 5.0V.

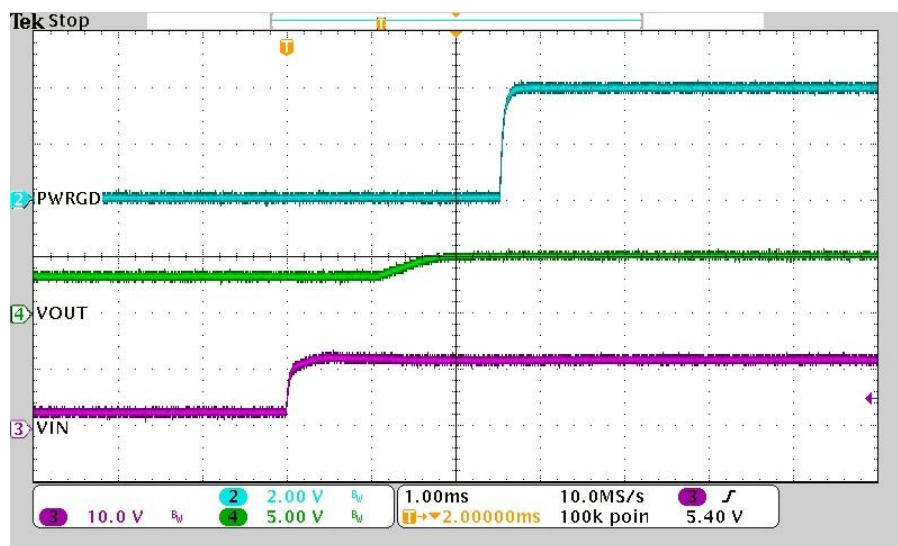

Fig. 7: Start-up with pre-bias 3.3V ($V_{OUT}=5V$, no load)

Start Up Voltage

By default, the THPM4601A will turn on when the input voltage reaches the startup voltage (V_{START}). The THPM4601A will turn off when the input voltage reduces to below the Under-Voltage Lock-Out (UVLO) level. Startup voltage cannot be reduced below the values provided in the table of Electrical Characteristics. Startup voltage can be increased using the EN pin, by an external resistor R_{EN} connected between EN and PGND. The value of V_{START} is given by equation (3):

$$V_{START} = 1.22 \times \frac{(100k\Omega + R_{EN})}{R_{EN}} \quad (3)$$

Enable input pin has almost 200mV hysteresis, the under-voltage shutdown point is determined by equation (4):

$$UVLO = 1.02 \times \frac{(100k\Omega + R_{EN})}{R_{EN}} \quad (4)$$

The value for R_{EN} for various start-up voltages is given in Table 2 as well as corresponding UVLO levels:

Table 2 – Startup and Shutdown Voltage

Startup Voltage	2.9V	4V	5V	6V	7V	8V	9V
Calculated R_{EN}	open	43.88k Ω	32.28k Ω	25.52k Ω	21.11k Ω	17.99k Ω	15.68k Ω
Standard R_{EN}	open	44.2k Ω	32.4k Ω	25.5k Ω	21.0k Ω	17.8k Ω	15.8k Ω
Under-voltage shutdown	2.6V	3.33V	4.17V	5.02V	5.88V	6.75V	7.48V

Power Good (PWRGD)

The PWRGD pin is an open drain output. Connect a pull up resistor (10kΩ to 100kΩ) between PWRGD pin and VCC pin, (or any logic voltage level lower than 3.6V). PWRGD signal becomes high almost 0.8ms after the output voltage reaches 92.5% of the programmed (set) output voltage. It becomes low when the output voltage is more than 20% below or more than 16% above the preset output voltage. Sensing output is through VADJ pin.

Soft Start Operation

Soft-start operation is internal to the THPM4601A. By default, the time delay between enabling a module (driving EN high) and the moment that PWRGD signal goes high is 2.5ms. That means the internally programmed start-up time is 1.7ms nominal (from asserting EN until Vout reaches 92.5% of its programmed value). Soft start time can be increased if required using an external capacitor on the SS/TRACK pin. For a soft start time of T_{SS} , the capacitor value, C_{SS} , is given by (5):

$$C_{SS}(nF) = 60 \times T_{SS}(ms) - 100 \quad (5)$$

For example, a 100nF capacitor will give a soft start time of 3.4ms nominal.

Tracking

If an external voltage is applied to the SS/TRACK pin (referenced to VOSNS-), it acts as a new reference voltage for the module and replaces the internal $V_{Ref} = 0.6V$. Also, the soft start settings are ignored. The external reference must be between 0.3V to 1.4V but during startup it must first reach 0.6V or above to ensure proper operation and then it can vary within the 0.3V-1.4V range. This feature is usually used for ramping of output voltage by applying a ramp up voltage to TRACK/SS pin or to implement tracking between two or more power supplies.

Input and Output Capacitance

Recommended input capacitance is composed of a bulk input capacitance of around 150μF (electrolytic) plus three 22μF thermally stable ceramic capacitors placed near VIN and PGND pins (at least X5R and 25V ratings). For output capacitance use four 22μF (X5R, 10V or higher) ceramic capacitors near the module and two parallel 47uF near load. These arrangements may be modified depending on the load requirements. Too low or too high capacitance on input or output or improper placement of capacitors can deteriorate the performance of the module.

Switching Frequency

The switching frequency is not adjustable and is internally set to be at 1 MHz typical. The frequency may change with the input voltage, output voltage, load or temperature. It may go down to as low as 700KHz range in very light load to reduce losses; or may increase to above 1.3MHz at full load and high temperature. Variations are relatively small at higher output voltage settings (Typically less than 10% for $V_{out} > 1.8V$).

Application Schematics

Fig. 8 shows a typical application schematic for 12V input and 3.3V output. Startup voltage is set to 9V using the resistor R_{EN} with value of 15.8k. If required, a MOSFET can also be connected to the EN pin, as shown in Fig.3 to provide on-off control.

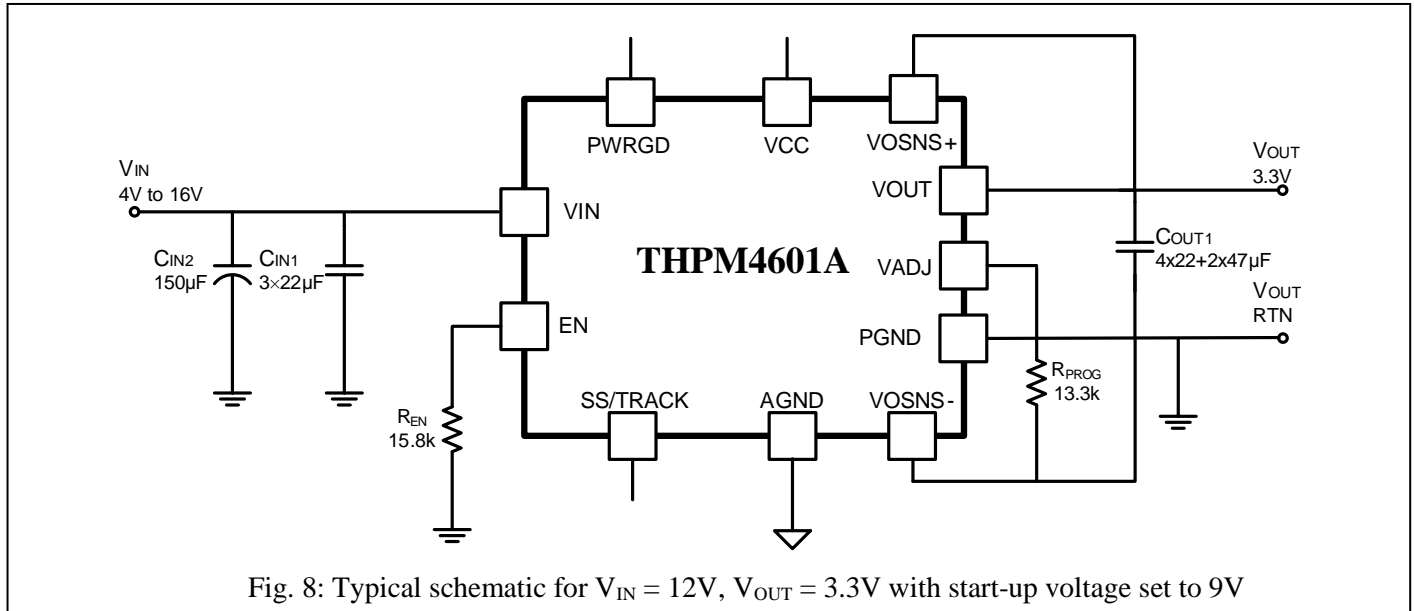

Sequencing Operation

The term sequencing is used when two or more separate modules or power supplies are configured to start one after the other, in sequence.

Sequencing operation between two or more THPM4601A power modules can be implemented with PWRGD pin and EN pin. Fig. 9 shows an example configuration when one THPM4601A (5.0V output) starts first and a second THPM4601A (2.5V output) starts after the output voltage of the first one has reached 5.0V. In this case, the Power Good signal (PWRGD) of the first module turns the second module ON through the EN pin.

The THPM4601A can start in sequence with another THPM4601A or any other POL having a compatible Power Good output or Enable input.

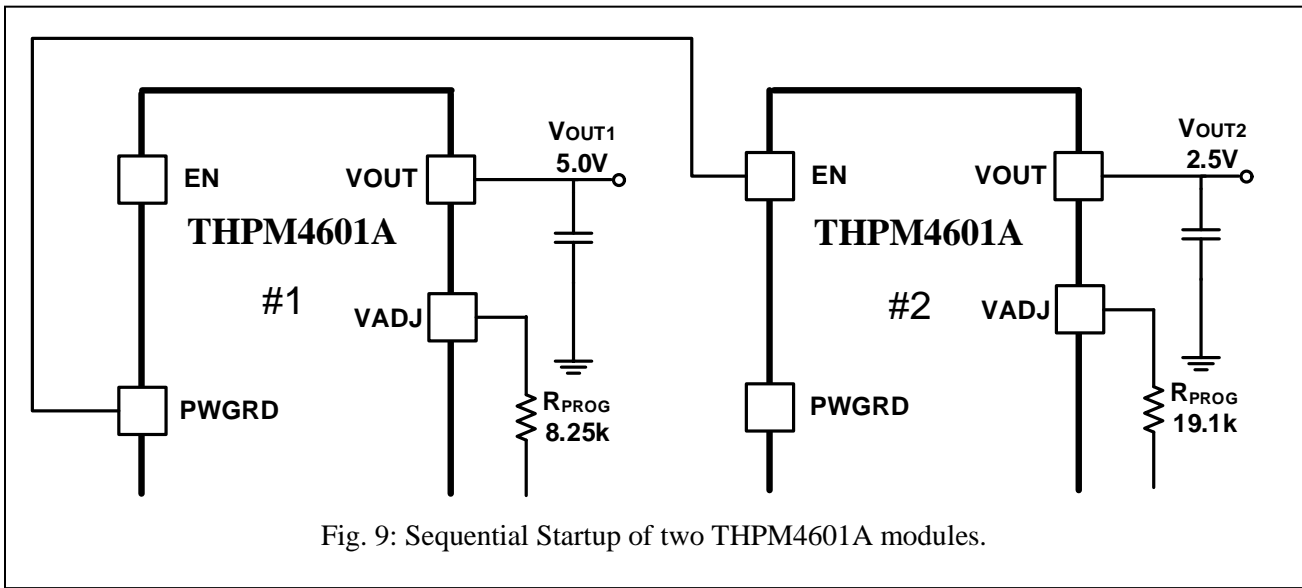

Fig. 9: Sequential Startup of two THPM4601A modules.

Fig.10 shows the output voltage waveforms of two THPM4601A modules used in sequential start-up mode. It shows that PWRGD signal (top trace) becomes high when the first THPM4601A enters into regulation (middle trace), and then the second THPM4601A starts up (bottom trace).

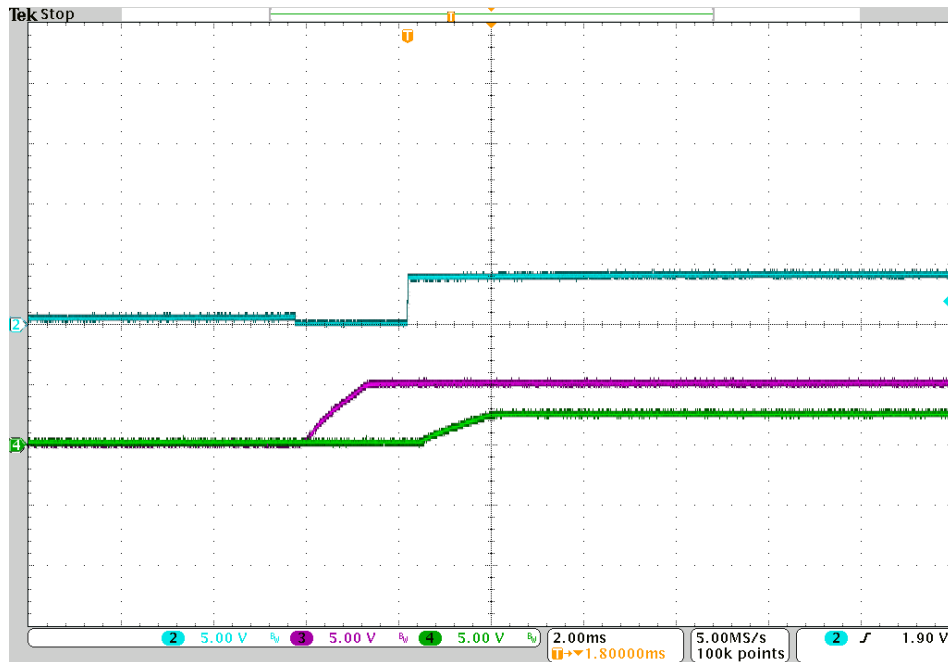

Fig. 10: Typical sequential startup waveform, $V_{OUT1} = 5V$, $V_{OUT2} = 2.5V$.

Transient Response

Fig.11 shows the measured transient waveform for a step change between 3A and 9A (6A step), for output voltage setting of 1.8V and input voltage of 12V. The slew rate for the load current change is 1A/ μ s. The peak transient voltage is approximately 28mV with a recovery time of 20 μ s.

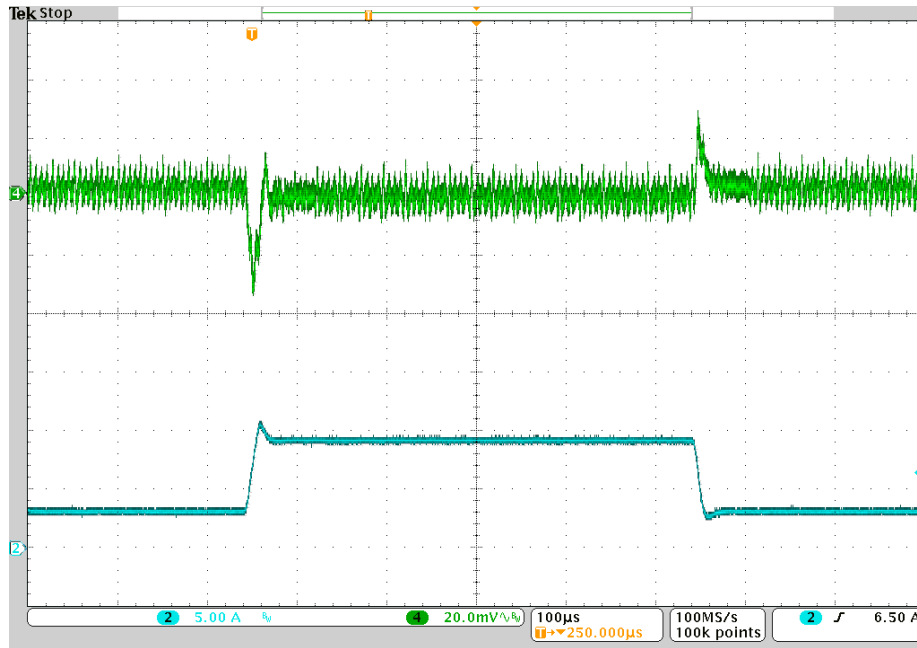

Fig. 11: Transient Response ($V_{IN} = 12V$, $V_{OUT} = 1.8V$) Slew rate 1A/ μ s

Over Current Protection

For protection against over-current faults, THPM4601A will shut down when the load current is higher than the over-current protection (OCP) level. During an over-current condition, THPM4601A will normally operate in hiccup mode and will try to re-start automatically. The hiccup operation will continue until the over-current condition is removed or input power is removed.

Fig. 12 shows the output voltage and output current waveforms during over-current protection operation for THPM4601A set to 5V output. Performance at other output voltage settings is similar. When the over-current condition is removed, the output voltage recovers automatically to the nominal voltage, as shown in Fig. 13

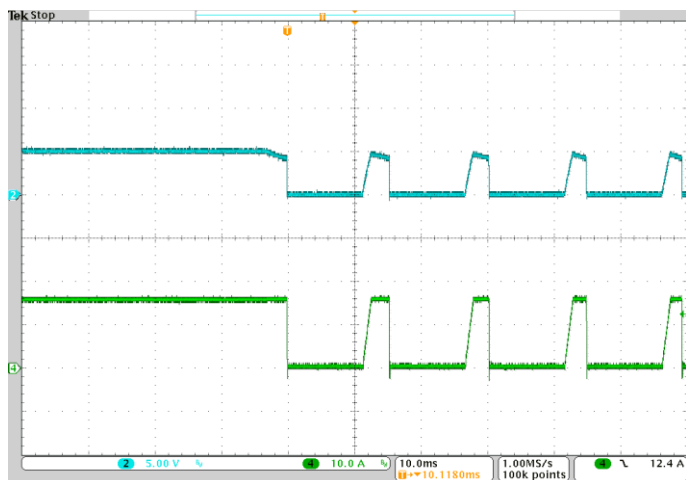

Fig. 12: Overcurrent protection (hiccup mode)

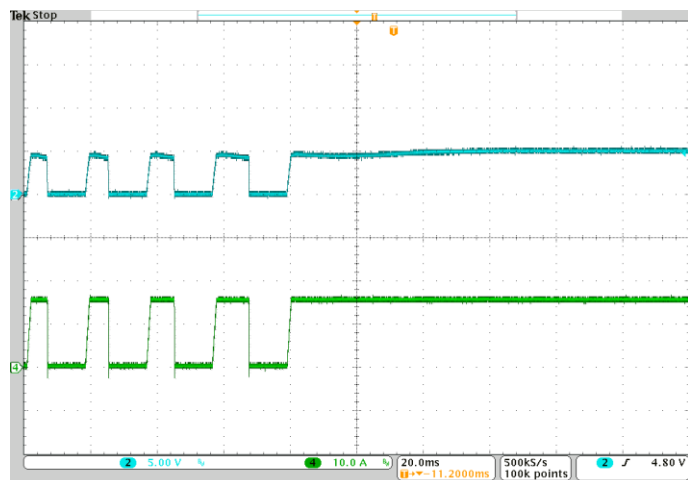

Fig. 13: Recovery from overcurrent

Input protection

In most applications, the input power source provides current limiting (typically fold-back or hiccup mode) and as long as the average fault current is limited to almost 10A or less, no further protection is required.

If the THPM4601A is powered from a battery or other high current source, it is recommended to include an external fuse (maximum 10A) in the input to the module. The THPM4601A includes full protection against output overcurrent or short-circuit, and the fuse will not operate under any output overload condition.

Thermal Considerations

The maximum continuous current rating depends on the ambient temperature and the airflow, as shown in Fig. 14. Output current can exceed the derated value for short periods.

The maximum rating is also influenced by the PCB layout; thermal performance can be improved by using more copper on the motherboard.

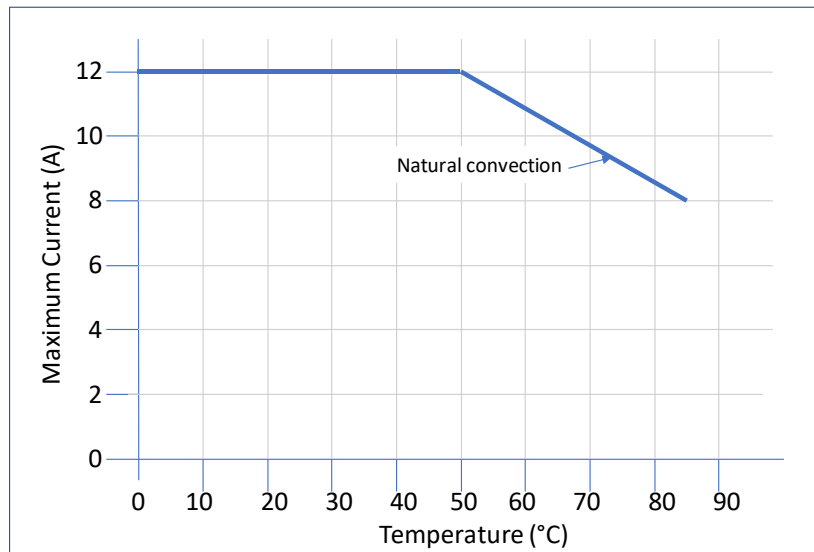

Fig. 14: Derating output current (12Vin, 5Vout). Less derating is needed for lower output voltages.

The absolute maximum operating junction temperature is 170°C and it is recommended to keep the operating temperature well below this value under worst-case conditions. Maximum recommended internal junction temperature is 125°C.

Thermal resistance from junction to ambient (θ_{JA}) is approximately 15°C/watt, measured on the EVM. The thermal resistance from case to ambient (θ_{CA}) depends on the PCB layout as well as the amount of cooling airflow.

The THPM4601A implements an internal thermal shutdown to protect itself against over-temperature conditions. If the junction temperature of the power MOSFET reaches approximately 160°C, the power module stops operating to protect itself from thermal damage. With a hysteresis of 30°C, when the temperature reduces to approximately 130°C, the THPM4601A will restart automatically.

Layout Considerations

To achieve optimal electrical and thermal performance, an optimized PCB layout is required. Some considerations for an optimized layout are:

- Use large copper areas for power planes (VIN, VOUT, and PGND) to minimize conduction loss and thermal stress;
- Place ceramic input and output capacitors close to the module pins to minimize high frequency noise. Share the same location on the PGND plane near module for the return paths of input and output capacitor currents and minimize the loop area between them;
- Locate additional output capacitors between the main ceramic capacitor and the load, placement of output capacitors can affect the performance of the module; use smaller ceramic capacitors closer to the module.
- Do not connect AGND and PGND planes as they are already connected inside the module;
- Place resistors and capacitors connected to VSENSE and VADJ pins as close as possible to their respective pins; Keep VOSNS+ and VOSNS- traces short, parallel and away from noisy areas. Avoid vias in their path to the load.
- Do not connect NC pins to other components;
- Use multiple vias to connect the power planes to internal layers.

Package Dimensions and PCB pads

ALL DIMENSIONS IN MILLIMETERS
 FLATNESS OF LGA PLANE: MAX 0.1mm

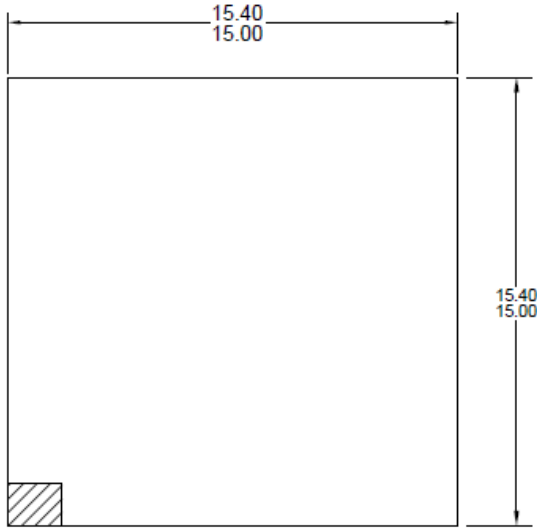

Package Top View

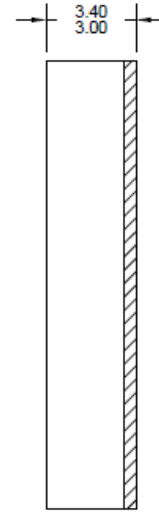

Package Side View

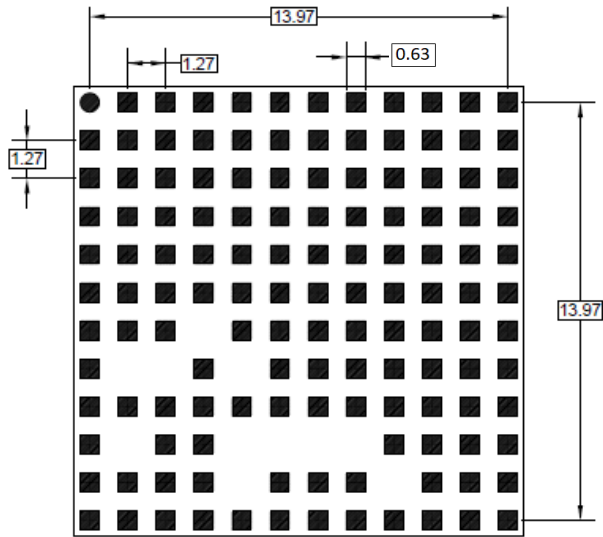

Package Bottom View
 (Total Pads: 133)

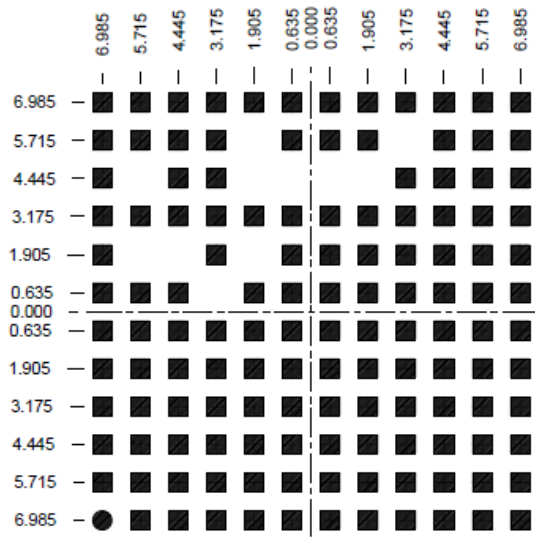

Suggested PCB Layout
 Top View

Notices and Requests

1. The product specifications described in this material are subject to change without prior notice.
2. The circuit diagrams described in this material are examples of the application which may not always apply to the customer's design. THine Electronics, Inc. ("THine") is not responsible for possible errors and omissions in this material. Please note even if errors or omissions should be found in this material, THine may not be able to correct them immediately.
3. This material contains THine's copyright, know-how or other intellectual property rights. Copying, reverse-engineer or disclosing to third parties the contents of this material without THine's prior written permission is prohibited.
4. THINE ACCEPTS NO LIABILITY FOR ANY DAMAGE OR LOSS IN CONNECTION WITH ANY DISPUTE RELATING TO INTELLECTUAL PROPERTY RIGHTS BETWEEN THE USER AND ANY THIRD PARTY, ARISING OUT OF THIS PRODUCT, EXCEPT FOR SUCH DAMAGE OR LOSS IN CONNECTION WITH DISPUTES SUCCESSFULLY PROVED BY THE USER THAT SUCH DISPUTES ARE DUE SOLELY TO THINE. NOTE, HOWEVER, EVEN IN THE AFOREMENTIONED CASE, THINE ACCEPTS NO LIABILITY FOR SUCH DAMAGE OR LOSS IF THE DISPUTE IS CAUSED BY THE USER'S INSTRUCTION.
5. This product is not designed for applications that require extremely high-reliability/safety such as aerospace device, nuclear power control device, or medical device related to critical care, excluding when this product is specified for automotive use by THine and used it for that purpose. THine accepts no liability whatsoever for any damages, claims or losses arising out of the uses set forth above.
6. Despite our utmost efforts to improve the quality and reliability of the product, faults will occur with a certain small probability, which is inevitable to a semi-conductor product. Therefore, you are encouraged to have sufficiently fail-safe design principles such as redundant or error preventive design applied to the use of the product so as not to have our product cause any social or public damage.
7. This product may be permanently damaged and suffer from performance degradation or loss of mechanical functionality if subjected to electrostatic charge exceeding capacity of the ESD (Electrostatic Discharge) protection circuitry. Safety earth ground must be provided to anything in contact with the product, including any operator, floor, tester and soldering iron.
8. Please note that this product is not designed to be radiation-proof.
9. Testing and other quality control techniques are used to this product to the extent THine deems necessary to support warranty for performance of this product. Except where mandated by applicable law or deemed necessary by THine based on the user's request, testing of all functions and performance of the product is not necessarily performed.
10. This product must be stored according to storage method which is specified in this specifications. THine accepts no liability whatsoever for any damage or loss caused to the user due to any storage not according to above-mentioned method.
11. Customers are asked, if required, to judge by themselves if this product falls under the category of strategic goods under the Foreign Exchange and Foreign Trade Act in Japan and the Export Administration Regulations in the United States of America on export or transit of this product. This product is prohibited for the purpose of developing military modernization, including the development of weapons of mass destruction (WMD), and the purpose of violating human rights.
12. The product or peripheral parts may be damaged by a surge in voltage over the absolute maximum ratings or malfunction, if pins of the product are shorted by such as foreign substance. The damages may cause a smoking and ignition. Therefore, you are encouraged to implement safety measures by adding protection devices, such as fuses. THine accepts no liability whatsoever for any damage or loss caused to the user due to use under a condition exceeding the limiting values.
13. All patents or pending patent applications, trademarks, copyrights, layout-design exploitation rights or other intellectual property rights concerned with this product belong to THine or licensor(s) of THine. No license or right is granted to the user for any intellectual property right or other proprietary right now or in the future owned by THine or THine's licensor. The user must enter into a license agreement with THine or THine's licensor to be granted of such license or right.

THine Electronics, Inc.

<https://www.thine.co.jp>